

# EVD mini

Superheat control for unipolar electronic expansion valve

# CAREL



**ENG** User manual

**LEGGI E CONSERVA  
QUESTE ISTRUZIONI**  
**READ AND SAVE  
THESE INSTRUCTIONS**

**NO POWER  
& SIGNAL  
CABLES  
TOGETHER**  
**READ CAREFULLY IN THE TEXT!**

High Efficiency Solutions



WARNINGS



CAREL bases the development of its products on decades of experience in HVAC, on the continuous investments in technological innovations to products, procedures and strict quality processes with in-circuit and functional testing on 100% of its products, and on the most innovative production technology available on the market. CAREL and its subsidiaries nonetheless cannot guarantee that all the aspects of the product and the software included with the product respond to the requirements of the final application, despite the product being developed according to start-of-the-art techniques. The customer (manufacturer, developer or installer of the final equipment) accepts all liability and risk relating to the configuration of the product in order to reach the expected results in relation to the specific final installation and/or equipment. CAREL may, based on specific agreements, acts as a consultant for the positive commissioning of the final unit/application, however in no case does it accept liability for the correct operation of the final equipment/system.

The CAREL product is a state-of-the-art product, whose operation is specified in the technical documentation supplied with the product or can be downloaded, even prior to purchase, from the website [www.carel.com](http://www.carel.com). Each CAREL product, in relation to its advanced level of technology, requires setup/configuration/programming/commissioning to be able to operate in the best possible way for the specific application. The failure to complete such operations, which are required/indicated in the user manual, may cause the final product to malfunction; CAREL accepts no liability in such cases. Only qualified personnel may install or carry out technical service on the product.

The customer must only use the product in the manner described in the documentation relating to the product.

In addition to observing any further warnings described in this manual, the following warnings must be heeded for all CAREL products:

- prevent the electronic circuits from getting wet. Rain, humidity and all types of liquids or condensate contain corrosive minerals that may damage the electronic circuits. In any case, the product should be used or stored in environments that comply with the temperature and humidity limits specified in the manual;
- do not install the device in particularly hot environments. Too high temperatures may reduce the life of electronic devices, damage them and deform or melt the plastic parts. In any case, the product should be used or stored in environments that comply with the temperature and humidity limits specified in the manual;
- do not attempt to open the device in any way other than described in the manual;
- do not drop, hit or shake the device, as the internal circuits and mechanisms may be irreparably damaged;
- do not use corrosive chemicals, solvents or aggressive detergents to clean the device;
- do not use the product for applications other than those specified in the technical manual.

All of the above suggestions likewise apply to the controllers, serial boards, programming keys or any other accessory in the CAREL product portfolio. CAREL adopts a policy of continual development. Consequently, CAREL reserves the right to make changes and improvements to any product described in this document without prior warning.

The technical specifications shown in the manual may be changed without prior warning.

The liability of CAREL in relation to its products is specified in the CAREL general contract conditions, available on the website [www.carel.com](http://www.carel.com) and/or by specific agreements with customers; specifically, to the extent where allowed by applicable legislation, in no case will CAREL, its employees or subsidiaries be liable for any lost earnings or sales, losses of data and information, costs of replacement goods or services, damage to things or people, downtime or any direct, indirect, incidental, actual, punitive, exemplary, special or consequential damage of any kind whatsoever, whether contractual, extra-contractual or due to negligence, or any other liabilities deriving from the installation, use or impossibility to use the product, even if CAREL or its subsidiaries are warned of the possibility of such damage.

DISPOSAL



INFORMATION FOR USERS ON THE CORRECT HANDLING OF WASTE ELECTRICAL AND ELECTRONIC EQUIPMENT (WEEE)

In reference to European Union directive 2002/96/EC issued on 27 January 2003 and the related national legislation, please note that:

1. WEEE cannot be disposed of as municipal waste and such waste must be collected and disposed of separately;
2. the public or private waste collection systems defined by local legislation must be used. In addition, the equipment can be returned to the distributor at the end of its working life when buying new equipment;
3. the equipment may contain hazardous substances: the improper use or incorrect disposal of such may have negative effects on human health and on the environment;
4. the symbol (crossed-out wheeled bin) shown on the product or on the packaging and on the instruction sheet indicates that the equipment has been introduced onto the market after 13 August 2005 and that it must be disposed of separately;
5. in the event of illegal disposal of electrical and electronic waste, the penalties are specified by local waste disposal legislation.

**Warranty on the materials:** 2 years (from the date of production, excluding consumables).

**Approval:** the quality and safety of CAREL INDUSTRIES products are guaranteed by the ISO 9001 certified design and production system, as well as by the marks (\*).

CAUTION: separate as much as possible the probe and digital input signal cables from the cables carrying inductive loads and power cables to avoid possible electromagnetic disturbance.

Never run power cables (including the electrical panel wiring) and signal cables in the same conduits.



READ CAREFULLY IN THE TEXT!



# Content

<b>1. INTRODUCTION</b>	<b>7</b>
1.1 Models.....	7
1.2 Functions and main characteristics.....	7
1.3 Accessories.....	7
<b>2. INSTALLATION</b>	<b>8</b>
2.1 Dimensions and mounting-mm (in).....	8
2.2 Description of the terminals.....	9
2.3 Wiring diagram for superheat control.....	10
2.4 Installation.....	10
2.5 Copy parameters with programming key.....	11
<b>3. USER INTERFACE</b>	<b>12</b>
3.1 Keypad.....	12
3.2 Display.....	12
3.3 Programming mode.....	12
3.4 Restore factory parameters (default).....	12
<b>4. COMMISSIONING</b>	<b>13</b>
<b>5. FUNCTIONS</b>	<b>15</b>
5.1 Control.....	15
5.2 Analogue positioner (0-10 Vdc).....	16
5.3 Superheat control with 2 temp. probes.....	16
5.4 Special functions.....	17
5.5 Regolazione speciale: smooth lines.....	17
5.6 Control parameters for protection functions.....	18
5.7 Service parameters.....	18
<b>6. PROTECTORS</b>	<b>19</b>
6.1 Protectors.....	19
<b>7. PARAMETERS TABLE</b>	<b>21</b>
<b>8. NETWORK CONNECTION</b>	<b>23</b>
8.1 RS485 serial configuration.....	23
8.2 Network connection for commissioning via PC.....	23
8.3 Visual parameter manager.....	23
8.4 Restore default parameters.....	24
8.5 Setup by direct copy.....	24
8.6 Setup using configuration file.....	25
8.7 Read the configuration file on the controller.....	25
8.8 Variables accessible via serial connection.....	26
8.9 Control states.....	27
8.10 Special control states.....	28
<b>9. ALARMS</b>	<b>30</b>
9.1 Types of alarms.....	30
9.2 Probe alarms.....	30
9.3 Control alarms.....	30
9.4 Valve emergency closing procedure.....	30
9.5 Network alarm.....	31
9.6 Alarm table.....	31
<b>10. TROUBLESHOOTING</b>	<b>32</b>
<b>11. TECHNICAL SPECIFICATIONS</b>	<b>34</b>



# 1. INTRODUCTION

EVD mini is a range of drivers designed for the control of CAREL single-pole electronic expansion valves used in refrigerant circuits. EVD mini controls refrigerant superheat and optimises refrigerant circuit performance; it guarantees significant system flexibility being compatible with various types of refrigerants, in applications with refrigerators and chiller/air-conditioners. It features low superheat protection (LowSH), high evaporation pressure (MOP) and low evaporation pressure (LOP) functions.

As regards network connectivity, the driver can be connected via serial RS485/ Modbus® to:

- a pCO programmable controller
- a CAREL supervisor.

Another possibility involves operation as a simple positioner with 0 to 10 Vdc analogue input signal, or as a manual positioner via RS485. EVD mini can be supplied with LED display for information on the instant superheat value and any active alarms, or for performing the commissioning operations. The latter involves setting just three parameters: refrigerant, operating mode (showcase, air conditioner, etc.) and superheat set point.

The driver can also be setup using a computer via the serial port. In this case, the VPM program (Visual Parameter Manager) needs to be installed, downloadable from <http://ksa.carel.com>, and the USB-RS485 converter connected.

## 1.1 Models

P/N	Description
EVDM001N00	EVD mini 24 V with display
EVDM000N00	EVD mini 24 V without display
EVDM010N00	EVD mini 115/230 V without display
EVDM011N00	EVD mini 115/230 V with display

Tab. 1.a

## 1.2 Functions and main characteristics

In summary:

- superheat control with LowSH, MOP, LOP functions;
- compatibility with various types of refrigerants;
- guided setup procedures first, entering just three parameters on the user interface: refrigerant (Gas), type of control (Mode) and superheat set point (Superheat);
- activation/deactivation of control via digital input or remote control via serial connection;
- controller and valve power supply incorporated (230 V/115 V);
- RS485 serial communication incorporated (Modbus protocol);
- IP65;
- operating conditions: -25T60°C (-13T140°F);
- compatible with Carel E2V and E3V single-pole valves.

From software revision 1.6 and higher, new functions have been introduced:

- hot gas bypass by pressure;
- hot gas bypass by temperature.

The smooth lines function has been introduced starting from software revision 1.8.

## 1.3 Accessories

Pressure probe cable (see technical leaflet +050000484), pressure probe (-1...9.3 barg, P/N SPKT0013P0) and temperature probe (P/N NTC006HP0R).



Fig. 1.a

The ratiometric pressure probe specified as default for assembly is P/N SPKT0013P0, with an operating range from -1 to 9.3 barg. Alternatively, other probes can be installed, setting the corresponding parameter accordingly. See the "Functions" chapter.

P/N	Type	P/N	Type
SPKT0053P0	-1...4.2 barg	SPKT00B6P0	0...45 barg
SPKT0013P0	-1...9.3 barg	SPKT00E3P0	-1...12.8 barg
SPKT0043P0	0...17.3 barg	SPKT00F3P0	0...20.7 barg
SPKT0033P0	0...34.5 barg		

Tab. 1.b

Single-pole valve (P/N E2V\*\*F\*\*C1/ E3V\*\*B\*\*C1)



Fig. 1.b

Ultracap module (P/N EVDMU\*\*N\*\*)

The module guarantees temporary power to the driver in the event of power failures, for enough time to immediately close the connected electronic valve. It avoids the need to install a solenoid valve. The module is made using Ultracap storage capacitors, which ensure reliability in terms of much longer component life than a module made with lead batteries.



Fig. 1.c

Ferrite (P/N 0907879AXX)

Clamp-on ferrite for use in certain applications. See the technical specifications table.



Fig. 1.d

Programming key with power supply (P/N IROPZKEYA0)

The key can be used to quickly program the controllers, reducing the risk of errors. This accessory also allows fast and effective technical service, and can be used for programming the controllers in just a few seconds, also during the testing phase.



Fig. 1.e

USB/RS485 converter (P/N CVSTDUMOR0)

The converter ensures connection between the computer used for configuration and the EVD mini driver.



Fig. 1.f

## 2. INSTALLATION

### 2.1 Dimensions and mounting-mm (in)

	Mounting on DIN rail:	with screws
EVD mini (24 V)	YES	YES
EVD mini (230 V)	YES	NO

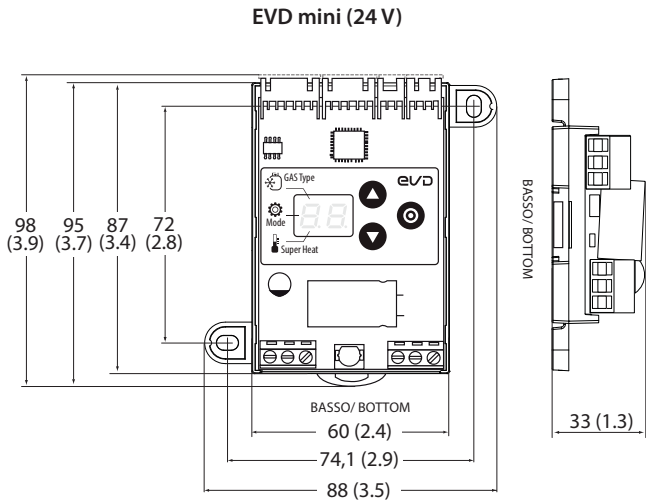

Fig. 2.a

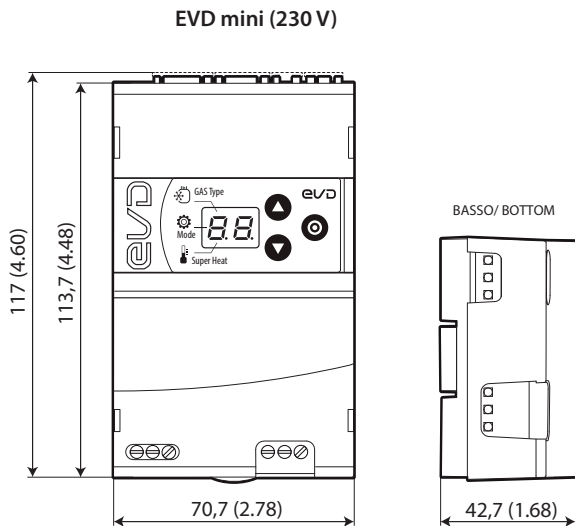

Fig. 2.b

#### On DIN rail mounting:

1. Fasten the DIN rail and fit the controller from point **(A)**;
2. 24V model: use a screwdriver to remove the two side slots before installing any other controllers alongside.

#### EVD mini (24 V)

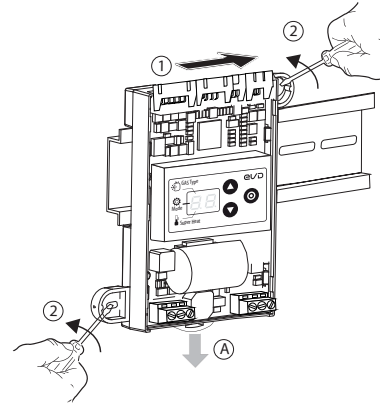

Fig. 2.c

#### EVD mini (230 V)

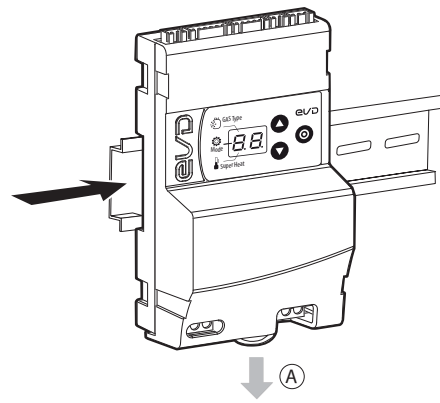

Fig. 2.d

#### Screw mounting

On the wall, mark the positions of the holes as per the figure and drill the holes ( $\varnothing < 4\text{mm}$ ). Then tighten the fastening screws.

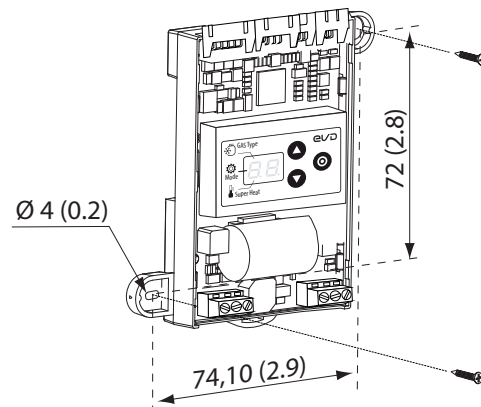

Fig. 2.e



## 2.2 Description of the terminals

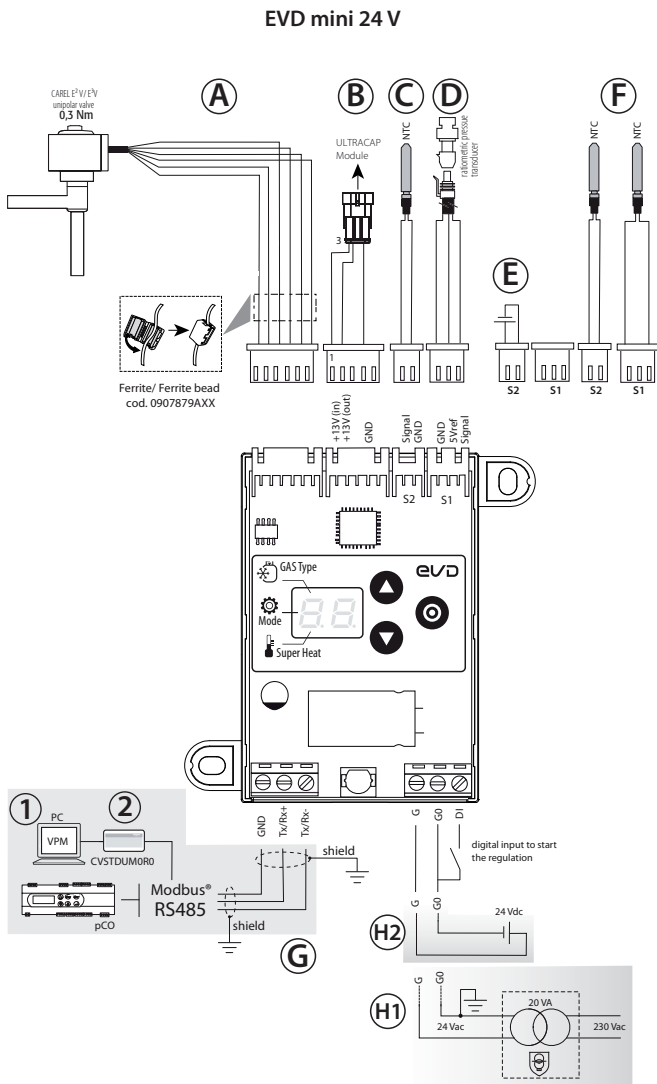

Fig. 2.f

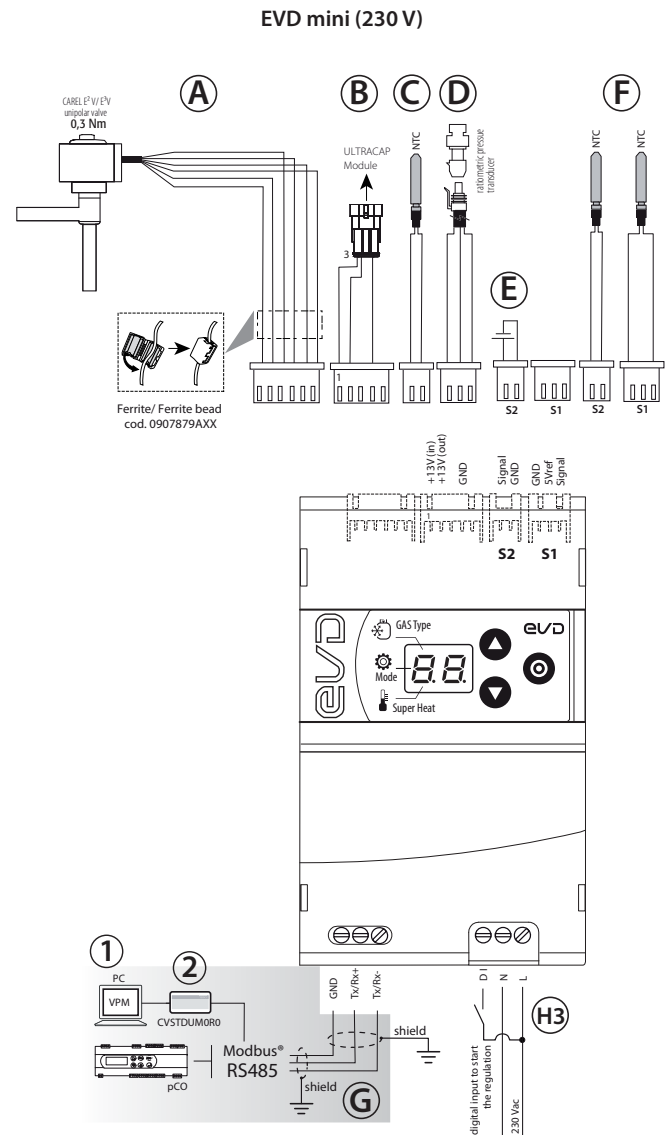

Fig. 2.a

Key:

Ref.	Terminal	Description
A	ExV	Single-pole valve connection
	+13 V (in)	
B	+13 V (out)	Ultracap module connection (accessory)
	GND	
C	Signal	S2 probe (temperature)
	Ground	Earth for S2 probe
D	GND	Earth for S1 probe
	5Vref	Power S1 active probe
	Signal	S1 probe: pressure or temperature
E	-	Connection as positioner (0 to 10 V input)
F	-	Connection for superheat control with 2 temperature probes
H1 (24 Vac power supply)	G	Power supply, 24 Vac
	G0	Power supply, 0 V ac
	DI	Digital input to enable control

Ref.	Terminal	Description
H2 (24 Vdc power supply)	G	Power supply, 24 Vdc
	G0	Power supply, 0 Vdc
	DI	Digital input to enable control
H3 (230 V power supply)	L	230 V power supply, line
	N	230 V power supply, neutral
	DI	230 V digital input to enable control
G	GND	
	Tx/ Rx +	Terminal for RS485 connection
	Tx/ Rx -	
1		PC for configuration
2		USB – RS485 Converter

Tab. 2.a

### 2.3 Wiring diagram for superheat control

- EVD mini requires the use of an evaporation pressure probe S1 and suction temperature probe S2, which will be fitted downstream of the evaporator, and a digital input to enable control. Alternatively, the signal to enable control can be sent via a remote RS485 connection;
- input S1 is programmable and connection to the terminals depends on the parameter settings. See the chapters "Commissioning" and "Functions".

**Note:** for details on installing probes, see the "EEV system guide" (+030220810).

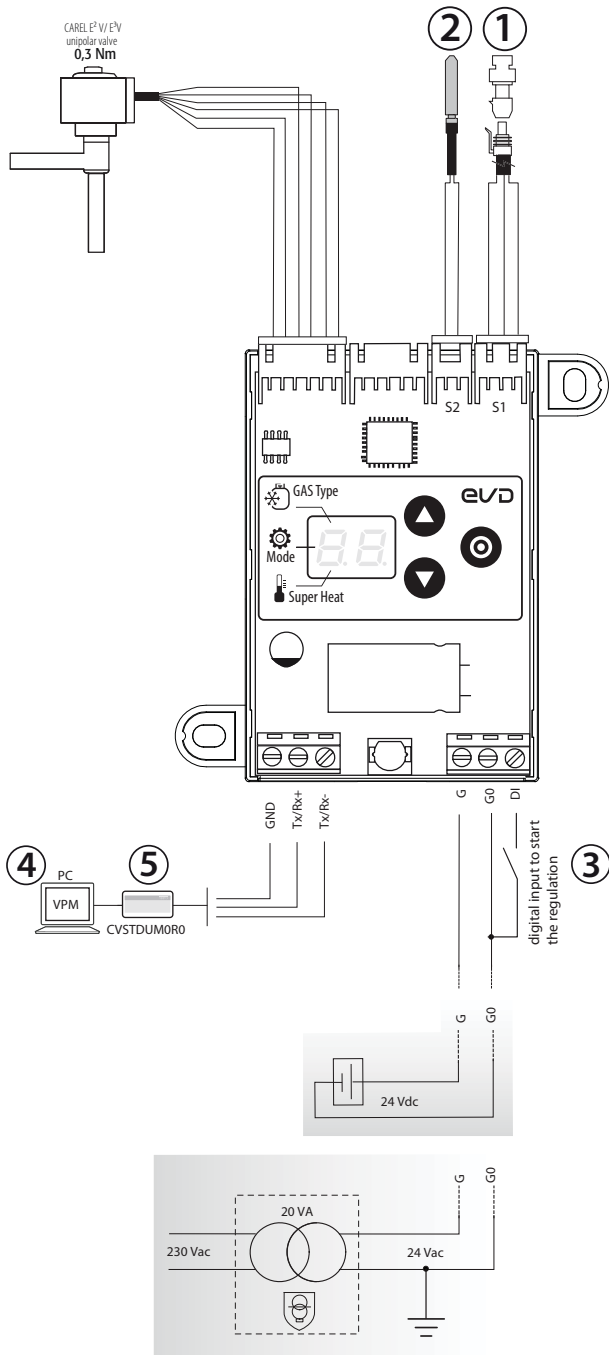

Fig. 2.g

Key:

- ① Ratiometric pressure transducer – evaporation pressure
- ② NTC – suction temperature
- ③ Digital input to enable control
- ④ Personal computer for configuration
- ⑤ USB / tLAN converter

### 2.4 Installation

For installation, proceed as shown below, with reference to the wiring diagrams and the technical specifications table:

- connect the probes: these can be installed up to a maximum distance of 10 m from the driver; select the pressure probe suitable for the refrigerant. For details on the recommended pressure probe for each refrigerant, see "Commissioning";
- connect any digital inputs, maximum length 10 m;
- connect the valve cable: it is recommended to use a maximum cable length of 1 m for E2V and E3V valves.
- the 24 V models can be powered at:
  - 24 Vac: use a class II safety transformer, adequately protected against short-circuits and overload. Transformer power must be between 20 and 50 VA, as shown in the technical specifications table;
  - 24 Vdc: use an external power supply, see technical specifications table;
- the connection cables must have a minimum cross-section of 0.35 mm<sup>2</sup>;
- power on the driver: the LED on the power supply/display comes on and the driver will be immediately operational, with the default parameters:
  - Refrigerant = R404A;
  - Type of control: multiplexed showcase/cold room;
  - Superheat set point = 11 K.
- program the driver, if necessary: see the "User interface" chapter;
- connect to the serial network where required. See the following diagrams for connecting the earth on the 24 V EVD mini models.

#### EVD mini 24 Vac in serial network

Case 1: multiple drivers connected in a network, inside the same electrical panel, powered by the same transformer

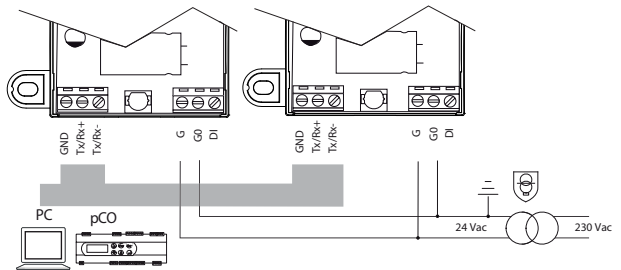

Fig. 2.h

Case 2: multiple drivers connected in a network, inside different electrical panels with the same earth point

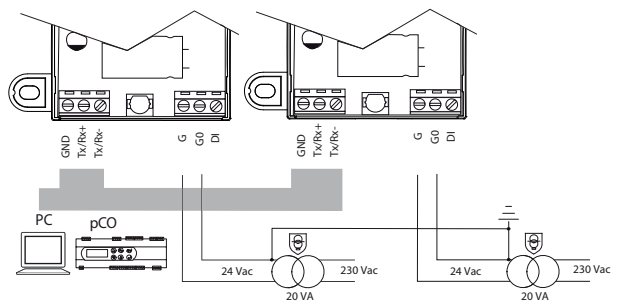

Fig. 2.i

**Important:** Earthing of G0 and G in driver EVD mini 24 Vac connected in serial network brings to permanent damage of the driver.

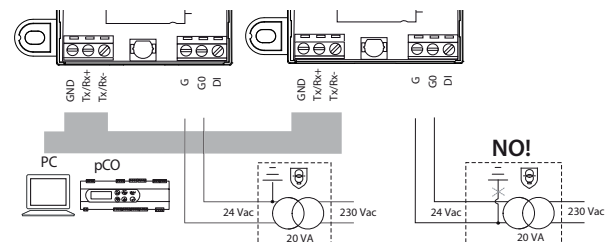

Fig. 2.j

**Installation environment**

**⚠ Important:** avoid installing the drivers in environments with the following characteristics:

- relative humidity greater than 90% or with condensation;
- strong vibrations or knocks;
- exposure to continuous water sprays;
- exposure to aggressive and polluting atmospheres (e.g.: sulphur and ammonia fumes, saline mist, smoke) to avoid corrosion and/or oxidation;
- strong magnetic and/or radio frequency interference (therefore avoid installing the devices near transmitting antennae);
- exposure of the driver to direct sunlight and to the elements in general.

**⚠ Important:** the following warnings must be observed when connecting the driver:

- if the driver is used in a way that is not specified in this user manual, protection cannot be guaranteed;
- incorrect power connections may seriously damage the driver;
- use cable ends suitable for the corresponding terminals. Loosen each screw and insert the cable ends, then tighten the screws and gently tug the cables to check they are sufficiently tight;
- separate as much as possible (at least 3 cm) the probe and digital input cables from power cables to avoid possible electromagnetic disturbance. Never run power cables (including the electrical panel cables) and probe signal cables in the same conduits;
- do not run probe signal cables in the immediate vicinity of power devices (contactors, circuit breakers, etc.). Reduce the path of probe cables as much as possible, and avoid spiral paths that enclose power devices;
- avoid powering the controller directly from the main power supply in the panel if this supplies different devices, such as contactors, solenoid valves, etc., which will require a separate transformer;
- \*EVD mini/ice is a controller to be incorporated into the final equipment; it must not be wall-mounted;
- \* DIN VDE 0100: protective separation must be guaranteed between the SELV circuits (Safety Extra Low Voltage) and the other circuits. The requirements of DIN VDE 0100 must be complied with. To prevent disruption of the protective separation (between the SELV circuits and the other circuits) ensure additional fastening near the terminations. This additional fastening must secure the insulation and not the wires.

**2.5 Copy parameters with programming key**

- ▶ Note:**
- The parameters must only be copied when the driver is NOT powered;
  - also see the programming key technical leaflet, P/N +050003930.

**Procedure:**

- A. Open the cover on the key using a screwdriver;
- B. Set the microswitches based on the operation :
  - UPLOAD: microswitches 2 = OFF,
  - DOWNLOAD: microswitches 1= OFF, microswitches 2 = ON
 See leaflet +050003930



Fig. 2.k

**EVD mini (24 V)**

**⚠ Important:** do not use a screwdriver to remove the cover on the display, to avoid damaging the board.

To remove the cover of the display:

- 1 Apply a pressure rightward on the left side of the cover.
- 2 Raise up the right side to extract it.
- 3 Plug the key into the provided connector, then perform the desired operation (UPLOAD/DOWNLOAD).

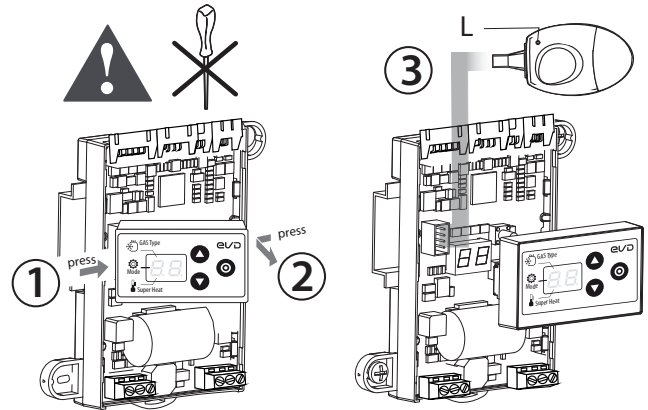

Fig. 2.l

**EVD mini (230 V)**

To remove the cover of the display:

- 1 Press with a screwdriver as shown in the figure, to remove the cover.
- 2 Lift the cover and remove it.
- 3 Plug the key into the provided connector, then perform the desired operation (UPLOAD/DOWNLOAD).

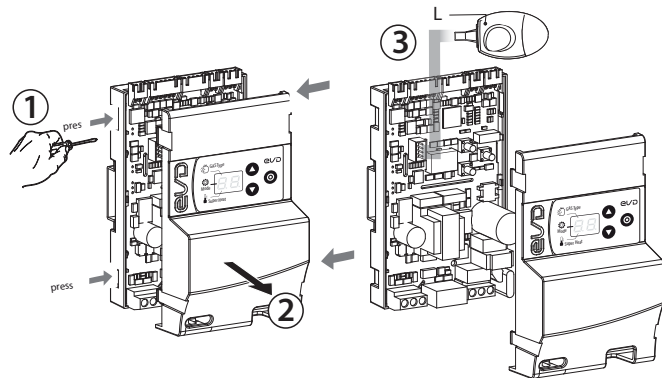

Fig. 2.m

### 3. USER INTERFACE

On models where featured, the user interface comprises the two-digit display and keypad with three buttons that, pressed alone or in combination, are used to perform all the configuration and programming operations on the driver.

#### Model without display

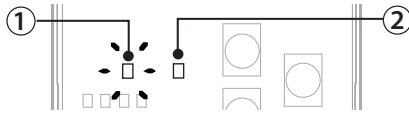

Fig. 3.a

①	Red LED - see "Alarms"
②	Green LED - power supply ON

#### Model with display

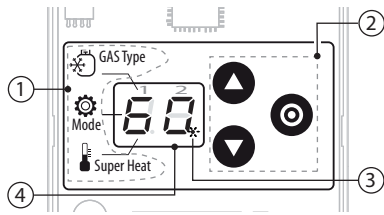

Fig. 3.b

Key	
①	Parameter label (for commissioning)
②	Keypad
③	Control ON/OFF digital input status LED
④	flashing/off = DI closed/open (*)
Two-digit display	

(\*) when the digital input is closed, the LED flashes and control is activated.

During commissioning/setup, the parameter label shows the meaning of the segments displayed in the first digit, corresponding to the three parameters being set:

- A. GAS Type: type of refrigerant;
- B. Mode: operating mode;
- C. Superheat: superheat set point.

See the "Commissioning" chapter.

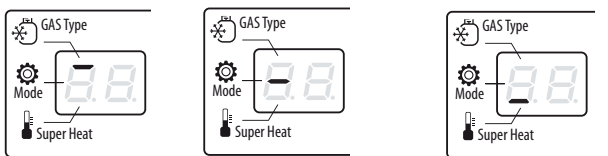

A. Refrigerant    B. Mode (operating mode)    C. Superheat set point

#### 3.1 Keypad

Key	Description
▲ / ▼	Increases/decreases the value of the set point or other selected parameter
UP    DOWN	menu navigation
⊙	at the end of the commissioning procedure, press for 2 s to exit and activate control;
PRG/Set	enter/exit control mode, saving the parameters;
	reset alarm E8

Tab. 3.b

#### 3.2 Display

During normal operation, the two-digit display shows the superheat measure and any alarms. If used as an analogue positioner, it displays the 0 to 10 V input value with decimal point. The display interval for the superheat value is -5 to 55 K (-9 to 99 °F). In general, values between -99 and 999 are displayed as follows:

1. values from 0 to 10 are displayed with decimal point and decimals;
2. values greater than 99 are displayed in two steps:
  - first, the hundreds, followed by "H"
  - then the tens and units.

3. values less than -9 are displayed in two steps:
  - first the "-" sign;
  - then the tens and units.

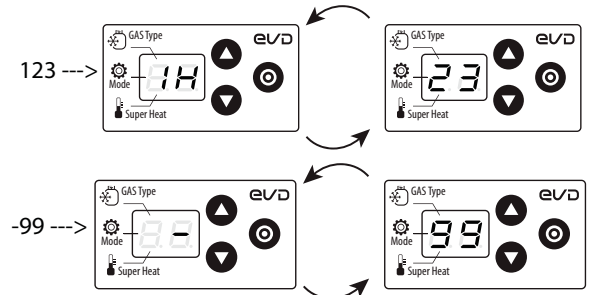

Fig. 3.c

#### 3.3 Programming mode

The parameters can be modified using the front keypad. Access depends on the user level: basic parameters (first configuration/setup) and Service parameters (Installer).

**⚠ Important: DO NOT** change the control parameters before completing the commissioning wizard, as described in chapter 4.

#### Modifying the Service parameters

The Service parameters include, in addition to the parameters for the configuration of input S1, those corresponding to the network address, probe readings, protectors and manual positioning. See the param. table. Procedure:

1. press UP and DOWN together and hold for more than 5 s: the first parameter is displayed: P1 = probe S1 reading;
2. press UP/ DOWN until reaching the desired parameter;
3. press PRG/ Set to display the value;
4. press UP/ DOWN to modify the value;
5. press PRG/ Set to confirm and return to the parameter code;
6. repeat steps 2 to 5 to modify other parameters;
7. (when the parameter code is displayed) press PRG/Set and hold for more than 2 s to exit the parameter setting procedure.

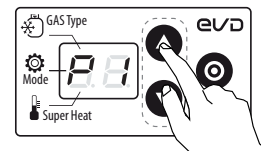

Fig. 3.d

**▶ Note:** if no button is pressed, after around 30 s the display automatically returns to standard visualisation.

#### 3.4 Restore factory parameters (default)

It is possible restore the controller to the default settings.

Procedure:

with the controller in standard display mode, press the three buttons together. After 5 seconds the display shows "rS". The reset procedure can be confirmed within 10 seconds, by pressing PRG/SET buttons for 3 seconds. If no button is pressed during this time, the procedure will be cancelled. At the end, the controller displays two dashes and then awaits the commissioning parameters.

# 4. COMMISSIONING

**Note:**

- If the controller does not have a display, see "Network connection";
- the default pressure probe is the ratiometric probe, with a measurement range of -1...9.3 barg;
- note the unit of measure (K/°F) when setting the superheat set point. To change the unit of measure, see the "Functions" chapter.

## 4.1 Commissioning procedure

Once the electrical connections have been completed (see the chapter "Installation") and the power supply has been connected, the operations required for commissioning the driver depend on the type of interface used, however essentially involve setting just 3 parameters: refrigerant, functioning mode, superheat setpoint.

**Important:**

- until the commissioning procedure has been completed, control will not be active;
- (only during commissioning) changing the refrigerant also means having to change the type of pressure probe.

Power on the driver: the display lights up and the driver awaits the commissioning parameters, as indicated by the bar on the display:

1. Refrigerant (default = 3: R404A);
2. Type of control (default = 1: multiplexed showcase/cold room);
3. Superheat set point (default= 11 K).

**Procedure:**

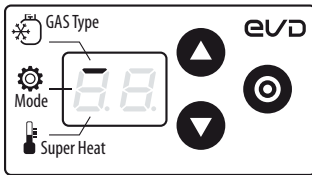

1. The display shows the bar at the top: refrigerant (GAS Type)

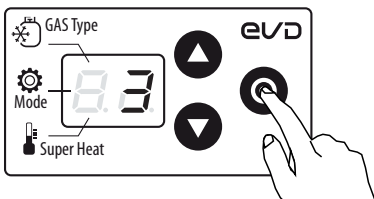

2. Press PRG/Set to display the refrigerant setting

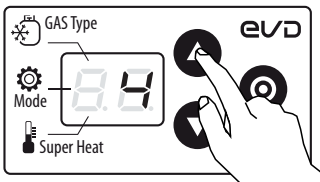

3. Press UP/DOWN to modify the value

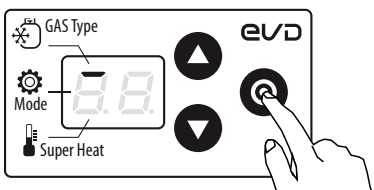

4. Press PRG to save the setting and return to the refrigerant parameter code (bar at top)

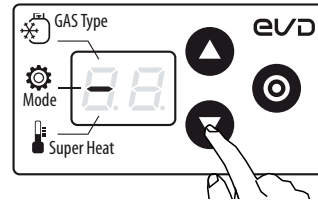

5. Press DOWN to move to the next parameter: Mode, indicated by the bar in the middle.

6. Repeat steps 2-4 to set superheat settings 1-7 and bypass 8-9;

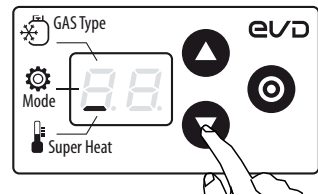

7. Press DOWN to move to the next parameter. For the superheat set point, the bar at the bottom is shown. Set the superheat set point;

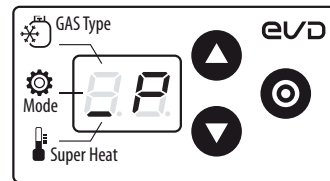

8. In the event of bypass control by pressure, parameter \_P is shown. Set the bypass pressure set point.

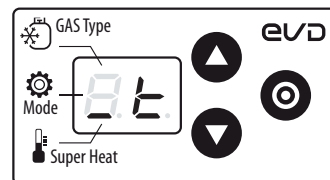

9. In the event of bypass control by temperature, parameter \_t is shown. Set the bypass temperature set point.

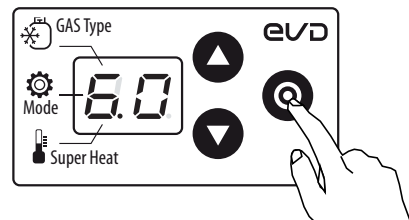

10. Press PRG/Set for 2 s to save the settings, exit programming mode and activate control. The standard display is shown.

### 4.5 Initial configuration parameters

**⚠ Important:** ONLY DURING COMMISSIONING, changing the refrigerant also means having to change the type of ratiometric probe; if not specified in the table, the ratiometric probe type is (-1 ... 9.3 barg).

#### Refrigerant

Parameter/ description					Def.	
Gas Type = refrigerant					3 = R404A	
0 = Custom						
1	R22	15	R422D	29		R455A (-1...12.8 barg)
2	R134a	16	R413A	30		R170 (0...17.3 barg)
3	R404A	17	R422A	31		R442A (-1...12.8 barg)
4	R407C	18	R423A	32		R447A (-1...12.8 barg)
5	R410A	19	R407A	33		R448A
6	R507A	20	R427A	34		R449A
7	R290	21	R245FA	35		R450A (-1...4.2 barg)
8	R600 (-1...4.2 barg)	22	R407F	36		R452A (-1...12.8 barg)
9	R600a (-1...4.2 barg)	23	R32 (0...17.3 barg)	37		R508B (-1...4.2 barg)
10	R717	24	HTR01	38		R452B
11	R744 (0...4.5 barg)	25	HTR02	39		R513A (-1...4.2 barg)
12	R728	26	R23	40		R454B
13	R1270	27	R1234yf			
14	R417A	28	R1234ze (-1...4.2 barg)			

**➡ Note:** if the refrigerant gas is not among those selectable for the "GAS Type = refrigerant" parameter:

1. set any refrigerant (e.g. R404);
2. select the type of main control, the superheat set point and complete the initial commissioning procedure;
3. use the VPM program (Visual Parameter Manager, see the chapter "Network connection") and set the type of refrigerant: "0 = custom" and the "Dew point a...f high/low" parameters that define the refrigerant;
4. start control, for example by closing the digital input contact.

#### Operating mode

Mode = Operating mode		
1	Multiplexed showcase/cold room	1 = Mul- tiplexed showcase/ cold room
2	Air-conditioner/chiller with plate heat exchanger	
3	Air-conditioner/chiller with tube bundle heat exchanger	
4	Air-conditioner/chiller with finned coil heat exchanger	
5	Analogue positioner (0 to 10 V)	
6	Superheat control with 2 temperature probes	
7	Subcritical CO2 showcase/cold room	
8	Hot gas bypass by pressure	
9	Hot gas bypass by temperature	

#### Set point

**➡ Note:** take into consideration the unit of measure (K/°F) when setting the superheat set point.

Superheat set point	11 K(20°F)
Bypass pressure set point	3 bar
Bypass temperature set point	10 °C

## 5. FUNCTIONS

### 5.1 Control

EVD mini is a superheat controller and can be used as an analogue positioner. The type of refrigeration unit can be selected using the "Operating mode" parameter.

Parameter/description	Def.
Operating mode	1 = multiplexed cabinet/cold room
1 Multiplexed cabinet/cold room	
2 Air-conditioner/chiller with plate heat exchanger	
3 Air-conditioner/chiller with tube bundle heat exchanger	
4 Air-conditioner/chiller with finned coil heat exchanger	
5 Analogue positioner (0 to 10V)	
6 Superheat control with 2 temperature probes	
7 Subcritical CO2 showcase/cold room	
8 Hot gas bypass by pressure	
9 Hot gas bypass by temperature	

Tab. 5.a

Based on the operating mode setting, the driver automatically sets a series of control parameters.

Operating mode	PID: proport. gain	PID: integration time	Superheat set point	LowSH protection		LOP protection		MOP protection		Bypass pressure: setpoint (bar)	Bypass temperature: setpoint (°C)
				th-reshold	Integra-tion time	th-reshold	Integra-tion time	th-reshold	Integra-tion time		
1 Multiplexed cabinet/cold room	15	150	11	5	15	-50	0	50	20		
2 Air-conditioner/chiller with plate heat exchanger	3	40	6	2	2,5	-50	4	50	10		
3 Air-conditioner/chiller with tube bundle heat exchanger	5	60	6	2	2,5	-50	4	50	10		
4 Air-conditioner/chiller with finned coil heat exchanger	10	100	6	2	10	-50	10	50	20		
5 Analogue positioner (0 to 10V)	-	-	-	-	-	-	-	-	-		
6 Superheat control with 2 temperature probes	15	150	11	5	15	-50	0	50	20		
7 Subcritical CO2 showcase/cold room	20	400	13	7	15	-50	0	50	20		
8 Hot gas bypass by pressure	20	200	-	-	-	-	-	-	-	3	-
9 Hot gas bypass by temperature	15	150	-	-	-	-	-	-	-	-	10

Tab. 5.b

### Superheat

The primary purpose of the electronic valve is ensure that the flow-rate of refrigerant that flows through the nozzle corresponds to the flow-rate required by the compressor. In this way, the evaporation process will take place along the entire length of the evaporator and there will be no liquid at the outlet (consequently in the branch that runs to the compressor). As liquid is not compressible, it may cause damage to the compressor and even breakage if the quantity is considerable and the situation lasts some time.

### Superheat control

The parameter that the control of the electronic valve is based on is the superheat temperature, which effectively tells whether or not there is liquid at the end of the evaporator. The superheat temperature is calculated as the difference between: superheated gas temperature (measured by a temperature probe located at the end of the evaporator) and the saturated evaporation temperature (calculated based on the reading of a pressure transducer located at the end of the evaporator and using the Tsat(P) conversion curve for each refrigerant).

$$\text{Superheat} = \text{Superheated gas temperature}^{(*)} - \text{Saturated evaporation temperature}$$

(\*) suction

If the superheat temperature is high it means that the evaporation process is completed well before the end of the evaporator, and therefore flow-rate of refrigerant through the valve is insufficient. This causes a reduction in cooling efficiency due to the failure to exploit part of the evaporator. The valve must therefore be opened further.

Vice-versa, if the superheat temperature is low it means that the evaporation process has not concluded at the end of the evaporator and a certain quantity of liquid will still be present at the inlet to the compressor.

The valve must therefore be closed further. The operating range of the superheat temperature is limited at the lower end: if the flow-rate through the valve is excessive the superheat measured will be near 0 K. This indicates the presence of liquid, even if the percentage of this relative to the gas cannot be quantified. There is therefore an undetermined risk to the compressor that must be avoided. Moreover, a high superheat temperature as mentioned corresponds to an insufficient flow-rate of refrigerant. The superheat temperature must therefore always be greater than 0 K and have a minimum stable value allowed by the valve-unit system.

A low superheat temperature in fact corresponds to a situation of probable instability due to the turbulent evaporation process approaching the measurement point of the probes. The expansion valve must therefore be controlled with extreme precision and a reaction capacity around the superheat set point, which will almost always vary from 3 to 14 K. Set point values outside of this range are quite infrequent and relate to special applications.

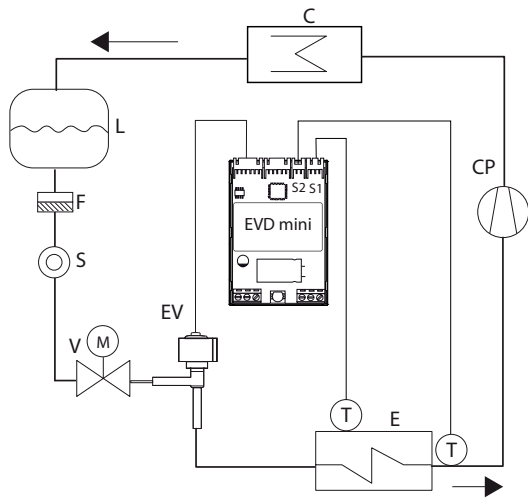

Fig. 5.a

Key

CP	compressor	EEV	electronic expansion valve
C	condenser	V	solenoid valve
L	liquid receiver	E	evaporator
F	dewatering filter	P	pressure probe (transducer)
S	liquid indicator	T	temperature probe

For the wiring, see "Wiring description".

PID parameters

Superheat control uses a PID algorithm. The control output is calculated as the sum of separate contributions: proportional and integral.

- the proportional action opens or closes the valve proportionally to the variation in the superheat temperature. Thus the greater the K (**proportional gain**) the higher the response speed of the valve. The proportional action does not consider the superheat set point, but rather only reacts to variations. Therefore if the superheat value does not vary significantly, the valve will essentially remain stationary and the set point cannot be reached;
- the integral action is linked to time and moves the valve in proportion to the deviation of the superheat value from the set point. The greater the deviations, the more intense the integral action; in addition, the lower the value of Ti (**integral time**), the more intense the action will be. The integral time, in summary, represents the intensity of the reaction of the valve, especially when the superheat value is not near the set point.

See the "EEV system guide" +030220810 for further information on calibrating PID control.

Par.	Description	Def.	Min.	Max.	UoM
Superheat	Superheat set point	11 (20)	LowSH: threshold	55 (99)	K(°F)
CP	PID proport. gain	15	0	800	-
ti	PID integral time	150	0	999	s

**Note:** when selecting the type of Mode, the PID control values suggested by CAREL will be automatically set for each application.

Control parameters for protection functions

See chapter on "Protectors".

5.2 Analogue positioner (0-10 Vdc)

The valve will be positioned linearly depending on the value of the "0 to 10 V input for analogue valve positioning" read by input S2. There is no PID control nor any protection (LowSH, LOP, MOP), and no valve unblock procedure. The opening of digital input DI stops control, and consequently forces the valve closed, switching operation to standby.

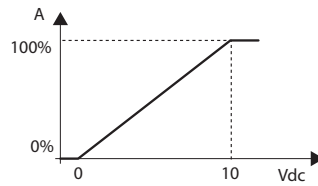
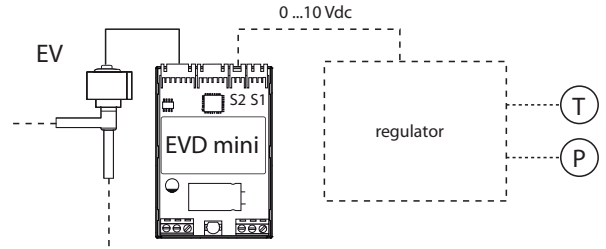

Fig. 5.b

Key:

EV	Electronic valve	A	Valve opening
----	------------------	---	---------------

For the wiring see chap. 2: "Description of the terminals".

**Important:** the pre-positioning and re-positioning procedures will not be performed. Manual positioning can in any case be enabled when control is active or in standby.

5.3 Superheat control with 2 temp. probes

The functional diagram is shown below. This type of control must be used with care, due to the lower precision of the temperature probe compared to the probe that measures the saturated evaporation pressure.

Parameter/ description	Def.
Mode = Operating mode	
... 6 = Superheat control with 2 temperature probes	1 = Multiplexed showcase/cold room

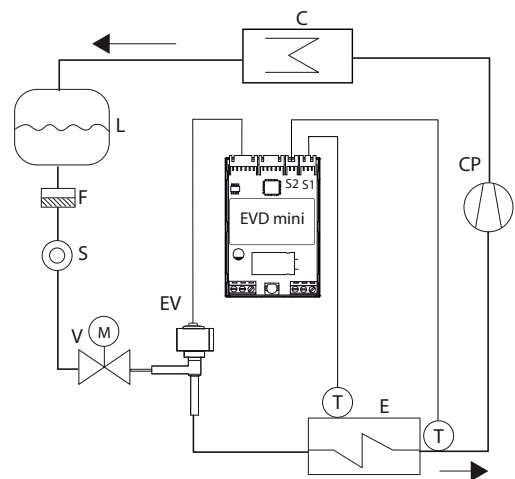

Fig. 5.e

Key:

CP	Compressor	V	Solenoid valve
C	Condenser	S	Liquid indicator
L	Liquid receiver	EV	Electronic valve
F	Dewatering filter	E	Evaporator
T	Temperature probe	S1	Evaporation temperature probe
S2	Suction temperature probe		

For the wiring see chap. 2: "Description of the terminals".



Par.	Description	Def	Min	Max	UOM
Superheat	Superheat set point	11(20)	LowSH: thresh.	55(99)	K
CP	PID: proportional gain	15	0	800	-
ti	PID: integral time	150	0	999	s

## 5.4 Special functions

### Hot gas bypass by pressure

This function can be used for cooling capacity control. If there is no request from circuit B, the compressor suction pressure decreases and the bypass valve opens, so as to deliver more hot gas and decrease circuit capacity.

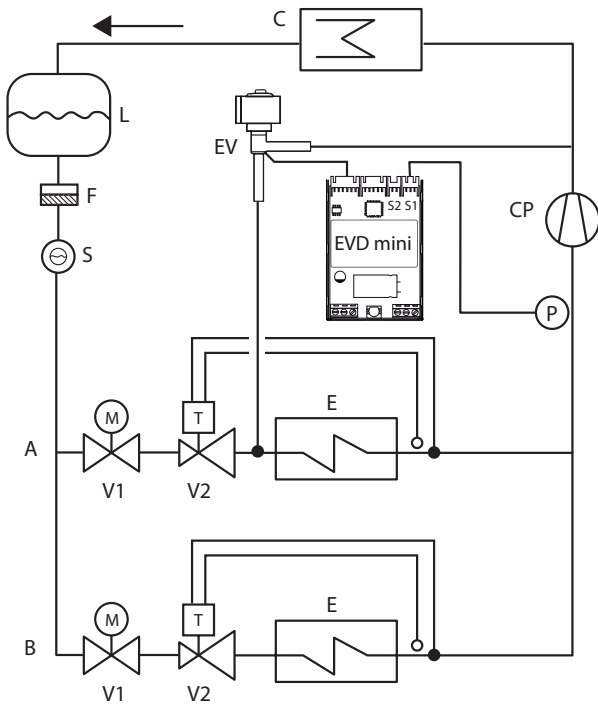

**Key**

CP	compressor	V1	solenoid valve
C	condenser	V2	thermostatic expansion valve
L	liquid receiver	EV	electronic valve
F	filter-drier	E	evaporator
S	liquid sightglass		

For the wiring see the "General connection diagram".

This is PID without any protection (LowSH, LOP, MOP, see the chapter on Protectors), no valve unblock procedure and no auxiliary control functions. The function uses the hot gas bypass pressure probe read by input S1, compared against the "Hot gas bypass pressure set point". Control is reverse: as the pressure increases, the valve closes and vice-versa.

Par.	Description	Def	Min	Max	UOM
_P	Hot gas bypass pressure set point	3	-20(290)	200(2900)	bar(psig)
CP	PID: proportional gain	15	0	800	-
ti	PID: integral time	150	0	999	s

### Hot gas bypass by temperature

This function can be used for cooling capacity control. On a showcase, if the room temperature probe detects an increase in temperature, cooling capacity needs to increase, so the valve must close.

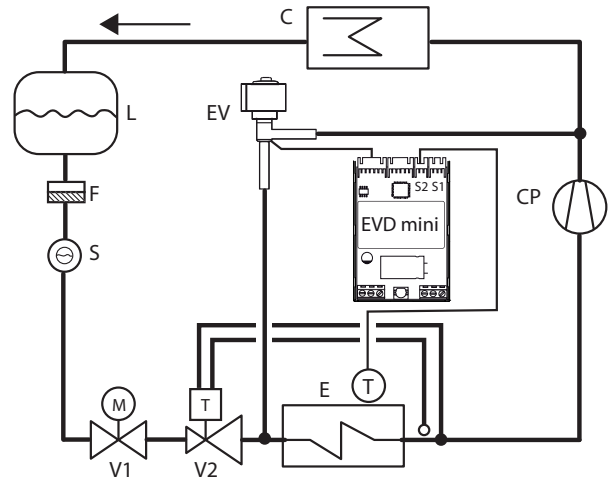

**Key**

CP	compressor	V1	solenoid valve
C	condenser	V2	thermostatic expansion valve
L	liquid receiver	EV	electronic valve
F	filter-drier	E	evaporator
S	liquid sightglass		

For the wiring see the "General connection diagram".

This is PID without any protection (LowSH, LOP, MOP, see the chapter on Protectors), no valve unblock procedure and no auxiliary control functions. The function uses the hot gas bypass temperature probe read by input S2, compared against the "Hot gas bypass temperature set point". Control is reverse: as the temperature increases, the valve closes and vice-versa.

Par.	Description	Def	Min	Max	UOM
_t	Hot gas bypass temperature set point	10	-85(-121)	200(392)	°C(°F)
CP	PID: proportional gain	15	0	800	-
ti	PID: integral time	150	0	999	s

## 5.5 Special control function: smooth lines



**Note:** the Smooth\_line parameter is only accessible via the supervisor.

The smooth lines function optimises evaporator capacity based on actual cooling demand, allowing more effective and stable control. The function completely eliminates traditional on/off control cycles, modulating the temperature exclusively using the electronic valve; superheat set point is controlled through a precise PI control algorithm based on the actual control temperature.

The master controller (connected via serial to EVD mini), through dynamic management of the Smooth\_line parameter, modifies the superheat set point for management of the electronic expansion valve, from a minimum (SH\_SET) to a maximum (SH\_SET + Smooth\_line): this consequently acts directly on the PID control algorithm that modifies the valve position. This is useful when the control temperature approaches the set point; the Smooth\_line parameter is used to prevent the valve from closing, by reducing the evaporator's cooling capacity.

In order to use this function, the digital input must be configured as BACKUP. The Smooth\_line parameter thus allows the control set point to be adjusted instantly.

In the event where there is no network connection, the Smooth\_line parameter is reset so as to resume normal control (START/STOP from digital input and SH\_SET as the superheat set point).

The main effects are:

- no swings in temperature and superheat due to the set point being reached;
- stable temperature and superheat control;
- maximum energy savings due to load stabilisation.

Par.	Description	Def.	Min.	Max.	UOM
di	DI configuration 1=start/stop - 2=control backup	1	1	2	-
Smooth_line	A: superheat set point offset for smooth lines	0	-99 (-55)	99 (55)	K/°F

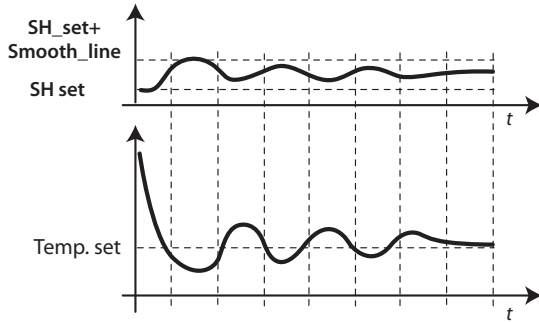

Key

SH set	Superheat set point	t	time
Temp.set	Temperature set point		

**Note:** the temperature setting based on the corresponding set point is managed by the master controller, while superheat control is managed by the EVD mini.

## 5.6 Control parameters for protection functions

See chapter on "Protectors".

## 5.7 Service parameters

The other configuration parameters, to be set where necessary before starting the controller, concern:

- the type of ratiometric pressure/temperature probe;
- the serial address for network connection;
- the type of unit of measure;
- enabling change in type of control (Mode);
- the number of steps (480/960) to control valve position.

### Type of pressure/temperature probe (par. S1)

S1 is used to select the type of ratiometric pressure or NTC probe.

Par.	Description	Def.	Min.	Max.	UOM
S1	Type of probe S1 1 = -1...4.2 barg 2 = 0.4...9.3 barg 3 = -1...9.3 barg 4 = 0...17.3 barg 5 = 0.85...34.2 barg 6 = 0...34.5 barg 7 = 0...45 barg 8 = -1...12.8 barg 9 = 0...20.7 barg 10 = 1.86...43.0 barg 11 = NTC (-50...105°C) 12 = Ratiometric (OUT=0-5V) 0-60 barg 13 = Ratiometric (OUT=0-5V) 0-90 barg 14 = Remote pressure probe from RS485	3	1	11	-

**Note:** the maximum and minimum limits for the pressure probe alarm can be set. See the parameter table.

### Network address (par. n1)

See chap. "Network connection"

### Unit of measure (par. Si)

The unit of measure used by the driver can be selected:

- S.I. (°C, K, barg);
- Imperial (°F, psig).

Par.	Description	Def.	Min.	Max.	UOM
Si	Unit of measure 1=°C/K/barg 2=°F/psig	1	1	2	-

**Note:** If the unit of measure K or °F relates to degrees Kelvin or Fahrenheit adopted for measuring the superheat and the related parameters.

When changing the unit of measure, all the values of the parameters saved on the driver and all the measurements read by the probes will be recalculated. This means that when changing the units of measure, control remains unaltered.

**Example 1:** The pressure read is 20 barg, this will be immediately converted to the corresponding value of 290 psig.

**Example 2:** The "superheat set point" parameter set to 10 K will be immediately converted to the corresponding value of 18 °F.

### Access to Mode parameter (par. IA)

To avoid accidental modification of the controller's operating mode, it is possible to disable the access to the corresponding mode parameter (mode).

Par.	Description	Def.	Min.	Max.	UOM
IA	Enable operating mode modification 0/1 = yes/ no	0	0	1	-

### Number of control steps (par. U3)

Total number of steps between the valve fully closed and fully open position

Par.	Description	Def.	Min.	Max.	UOM
U3	Number of valve control steps 1 / 2 = 480/960 steps	1	1	2	-

### Digital input

The digital input function can be set by parameter:

Par.	Description	Def.	Min.	Max.	UOM
di	DI configuration  1=Start/stop control; 2=Control backup	1	1	2	-

#### Start/Stop control:

- digital input closed: control activated;
- digital input open: driver in standby (see paragraph "Control status");

**Important:** this setting excludes activation/deactivation of control from the network. See the next setting.

**Control backup:** when connected to a network, in the event of communication failures, the driver verifies the status of the digital input to determine whether control is activated or in standby.

## 6. PROTECTORS

These are additional functions that are activated in specific situations that are potentially dangerous for the unit being controlled. They feature an integral action, that is, the action increases gradually when moving away from the activation threshold. They may add to or overlap (disabling) normal PID superheat control. By separating the management of these functions from PID control, the parameters can be set separately, allowing, for example, normal control that is less reactive yet much faster in responding when exceeding the activation limits of one of the protectors.

### 6.1 Protectors

The protectors are 3:

- LowSH, low superheat;
- LOP, low evaporation temperature;
- MOP, high evaporation temperature;

The protectors have the following main features:

- activation threshold: depending on the operating conditions of the controlled unit, this is set in Service programming mode;
- integration time, which determines the intensity (if set to 0, the protector is disabled): set automatically based on the type of main control;
- alarm, with activation threshold (the same as the protector) and timeout (if set to 0 disables the alarm signal).

**Note:** The alarm signal is independent from the effectiveness of the protector, and only signals that the corresponding threshold has been exceeded. If a protector is disabled (null integration time), the relative alarm signal is also disabled.

Each protector is influenced by the proportional gain parameter (CP) of PID superheat control. The higher is the value of CP, the more intensely the protection will react.

#### Characteristics of the protectors

Protection	Reaction	Reset
LowSH	Intense closing	Immediate
LOP	Intense opening	Immediate
MOP	Moderate closing	Controlled

Tab. 6.a

**Reaction:** summary description of the type of action in controlling the valve.

**Reset:** summary description of the type of reset following the activation of the protector. Reset is controlled to avoid swings around the activation threshold or immediate reactivation of the protector.

**Note:** all the alarms are generated after a fixed delay, as shown in the table:

Protectors	Delay (s)
LowSH	300
LOP	300
MOP	600

#### LowSH (low superheat)

The protector is activated so as to prevent the low superheat from causing the return of liquid to the compressor.

Par.	Description	Def.	Min.	Max.	U.M.
C1	LowSH protection: threshold	5(9)	-5(-9)	Set point superheat	K(°F)
C2	LowSH protection: integration time	15	0	800	s

When the superheat value falls below the threshold, the system enters low superheat status, and the intensity with which the valve is closed is increased: the more the superheat falls below the threshold, the more intensely the valve will close. The LowSH threshold must be less than or equal to the superheat set point. The low superheat integration time indicates the intensity of the action: the lower the value, the more intense the action.

**The integration time is set automatically based on the type of main control.**

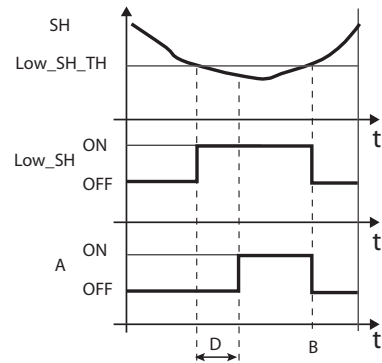

Fig. 6.a

key:

SH	Superheat	A	Alarm
Low_SH_TH	Low_SH protection threshold	D	Alarm delay
Low_SH	Low_SH protection	t	Time
B	Alarm automatic reset		

#### LOP (low evaporation pressure)

LOP= Low Operating Pressure

The LOP protection threshold is applied as a saturated evaporation temperature value so that it can be easily compared against the technical specifications supplied by the manufacturers of the compressors. The protector is activated so as to prevent too low evaporation temperatures from stopping the compressor due to the activation of the low pressure switch. The protector is very useful in units with compressors on board (especially multi-stage), where when starting or increasing capacity the evaporation temperature tends to drop suddenly.

When the evaporation temperature falls below the low evaporation temperature threshold, the system enters LOP status and is the intensity with which the valve is increased. The further the temperature falls below the threshold, the more intensely the valve will open. The integration time indicates the intensity of the action: the lower the value, the more intense the action.

Par.	Description	Def.	Min.	Max.	U.M.
C3	LOP protection: threshold	-50 (-58)	-85 (-121)	MOP protec.: threshold	C(°F)
C4	LOP protection: integration time	0	0	800	s

**The integration time is set automatically based on the type of main control.**

**Note:**

- the LOP threshold must be lower than the rated evaporation temperature of the unit, otherwise it would be activated unnecessarily, and greater than the calibration of the low pressure switch, otherwise it would be useless. As an initial approximation it can be set to a value exactly half-way between the two limits indicated;
- the protector has no purpose in multiplexed systems (showcases) where the evaporation is kept constant and the status of the individual electronic valve does not affect the pressure value;
- the LOP alarm can be used as an alarm to highlight refrigerant leaks by the circuit. A refrigerant leak in fact causes an abnormal lowering of the evaporation temperature that is proportional, in terms of speed and extent, to the amount of refrigerant dispersed.

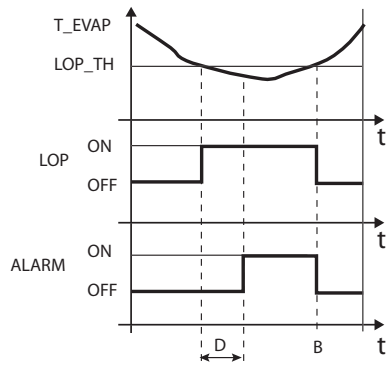

Fig. 6.b

Key:

T_EVAP	Evaporation temperature	D	Alarm timeout
LOP_TH	Low evaporation temperature protection	ALARM	Alarm
LOP	LOP protection	t	Time
B	Automatic alarm reset		

**MOP (high evaporation pressure)**

MOP= Maximum Operating Pressure.

The MOP protection threshold is applied as a saturated evaporation temperature value so that it can be easily compared against the technical specifications supplied by the manufacturers of the compressors. The protector is activated so as to prevent too high evaporation temperatures from causing an excessive workload for the compressor, with consequent overheating of the motor and possible activation of the thermal protector. The protector is very useful in self-contained units if starting with a high refrigerant charge or when there are sudden variations in the load. The protector is also useful in multiplexed systems (showcases), as allows all the utilities to be enabled at the same time without causing problems of high pressure for the compressors. To reduce the evaporation temperature, the output of the refrigeration unit needs to be decreased. This can be done by controlled closing of the electronic valve, implying superheat is no longer controlled, and an increase in the superheat temperature. The protector will thus have a moderate reaction that tends to limit the increase in the evaporation temperature, keeping it below the activation threshold while trying to stop the superheat from increasing as much as possible. Normal operating conditions will not resume based on the activation of the protector, but rather on the reduction in the refrigerant charge that caused the increase in temperature. The system will therefore remain in the best operating conditions (a little below the threshold) until the load conditions change.

Par.	Description	Def.	Min.	Max.	U.M.
C5	MOP protection threshold	50 (122)	Protection LOP: threshold	200 (392)	C(°F)
C6	MOP protection integration time	20	0	800	s

**The integration time is set automatically based on the type of main control.**

When the evaporation temperature rises above the MOP threshold, the system enters MOP status, superheat control is interrupted to allow the pressure to be controlled, and the valve closes slowly, trying to limit the evaporation temperature.

As the action is integral, it depends directly on the difference between the evaporation temperature and the activation threshold. The more the evaporation temperature increases with reference to the MOP threshold, the more intensely the valve will close. The integration time indicates the intensity of the action: the lower the value, the more intense the action.

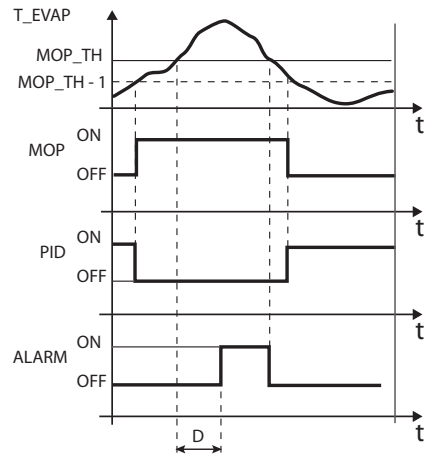

Fig. 6.c

Key:

T_EVAP	Evaporation temperature	MOP_TH	MOP threshold
PID	PID superheat control	ALARM	Alarm
MOP	MOP protection	t	Time
D	Alarm timeout		

**! Important:** the MOP threshold must be greater than the rated evaporation temperature of the unit, otherwise it would be activated unnecessarily. The MOP threshold is often supplied by the manufacturer of the compressor. It is usually between 10 °C and 15 °C.

If the closing of the valve also causes an excessive increase in the suction temperature (S2) above the set threshold – set via parameter (C7), not on the display - the valve will be stopped to prevent overheating the compressor windings, awaiting a reduction in the refrigerant charge. If the MOP protection function is disabled by setting the integral time to zero, the maximum suction temperature control is also deactivated.

Par.	Description	Def.	Min.	Max.	U.M.
C7	MOP protection: disabling threshold	30 (86)	-85 (-121)	200 (392)	°C (°F)

At the end of the MOP protection function, superheat regulation restarts in a controlled manner to prevent the evaporation temperature from exceeding the threshold again.

## 7. PARAMETERS TABLE

Par.	Description	Def.	Min.	Max.	UOM	Type	Carel	Modbus®	R/W	Note
<b>BASIC (INITIAL CONFIGURATION)</b>										
GAS Type	Refrigerant	3	1	41	-	I	12	139	R/W	
	1 R22	15	R422D	29	R455A (-1...12.8 barg)					
	2 R134a	16	R413A	30	R170 (0...17.3 barg)					
	3 R404A	17	R422A	31	R442A (-1...12.8 barg)					
	4 R407C	18	R423A	32	R447A (-1...12.8 barg)					
	5 R410A	19	R407A	33	R448A					
	6 R507A	20	R427A	34	R449A					
	7 R290	21	R245FA	35	R450A (-1...4.2 barg)					
	8 R600(-1...4.2 barg)	22	R407F	36	R452A (-1...12.8 barg)					
	9 R600a (-1...4.2 barg)	23	R32 (0...17.3 barg)	37	R508B (-1...4.2 barg)					
	10 R717	24	HTR01	38	R452B					
	11 R744 (0...45 barg)	25	HTR02	39	R513A (-1...4.2 barg)					
	12 R728	26	R23	40	R454B					
	13 R1270	27	R1234yf	41	R458A					
	14 R417A	28	R1234ze (-1...4.2 barg)							
Mode	Operating mode	1	1	9	-	I	13	140	R/W	
	1 Multiplexed cabinet/cold room									
	2 Air-conditioner/chiller with plate heat exchanger									
	3 Air-conditioner/chiller with tube bundle heat exchanger									
	4 Air-conditioner/chiller with finned coil heat exchanger									
	5 Analogue positioner (0 to 10V)									
	6 Superheat control with 2 temperature probes									
	7 Subcritical CO2 showcase/cold room									
	8 Hot gas bypass by pressure									
	9 Hot gas bypass by temperature									
Super Heat	Superheat set point	11 (20)	LowSH	55 (99)	K (°F)	A	10	9	R/W	
_P	Hot gas bypass pressure set point	3	-20(-290)	200(2900)	barg (psig)	A	23	22	R/W	
_t	Hot gas bypass temperature set point	10	-85(-121)	200(392)	°C(°F)	A	22	21	R/W	
<b>SERVICE</b>										
P1	Probe S1 reading	-	-85 (-290)	200 (2900)	barg (psig)	A	6	5	R	
P2	Probe S2 reading	-	-85 (-121)	200 (392)	°C(°F)/V	A	7	6	R	
tE	Evaporation temperature (converted)	-	-85 (-121)	200 (392)	°C(°F)	A	4	3	R	
tS	Suction temperature	-	-85 (-121)	200 (392)	°C(°F)	A	3	2	R	
Po	Valve opening	-	0	100	%	A	1	0	R	
CP	PID: proportional gain	15	0	800	-	A	11	10	R/W	
ti	PID: integral time	150	0	999	s	I	17	144	R/W	
C1	LowSH protection: threshold	5(9)	-5 (-9)	Superh. set point	K (°F)	A	12	11	R/W	
C2	LowSH protection: integral time	15	0	800	s	A	13	12	R/W	
C3	LOP protection: threshold	-50(-58)	-85(-121)	MOP protection: threshold	°C (°F)	A	14	13	R/W	
C4	LOP protection: integral time	0	0	800	s	A	15	14	R/W	
C5	MOP protection: threshold	50 (122)	LOP protection: threshold	200 (392)	°C (°F)	A	16	15	R/W	
C6	MOP protection: integral time	20	0	800	s	A	17	16	R/W	
C7	MOP protection: disabling threshold	30 (86)	-85 (-121)	200 (392)	°C (°F)	A	19	18	R/W	
C8	Low suction temperature alarm threshold	-50 (-58)	-85 (-121)	200 (392)	°C (°F)	A	18	17	R/W	
S1	Type of probe S1 Ratiometric (OUT=0...5V)	3	1	11	-	I	14	141	R/W	
	1 = -1...4.2 barg		8 = -1...12.8 barg							
	2 = 0.4...9.3 barg		9 = 0...20.7 barg							
	3 = -1...9.3 barg		10 = 1.86...43.0 barg							
	4 = 0...17.3 barg		11 = NTC (-50...105°C)							
	5 = 0.85...34.2 barg		12 = Ratiometric (OUT=0-5V) 0-60 barg							
	6 = 0...34.5 barg		13 = Ratiometric (OUT=0-5V) 0-90 barg							
	7 = 0...45 barg		14 = Remote pressure probe from RS485							
n1	Network address	99	1	99	-	I	10	137	R/W	

Par.	Description	Def.	Min.	Max.	UOM	Type	Carel	Modbus®	R/W	Note
n2	Baud rate (bit/s)	2	0	17	-	I	20	147	R/W	
	0   4800, 2 stop bit, parity none   9   4800, 1 stop bit, parity even									
	1   9600, 2 stop bit, parity none   10   9600, 1 stop bit, parity even									
	2   19200, 2 stop bit, parity none   11   19200, 1 stop bit, parity even									
	3   4800, 1 stop bit, parity none   12   4800, 2 stop bit, parity odd									
	4   9600, 1 stop bit, parity none   13   9600, 2 stop bit, parity odd									
	5   19200, 1 stop bit, parity none   14   19200, 2 stop bit, parity odd									
	6   4800, 2 stop bit, parity even   15   4800, 1 stop bit, parity odd									
	7   9600, 2 stop bit, parity even   16   9600, 1 stop bit, parity odd									
8   19200, 2 stop bit, parity even   17   19200, 1 stop bit, parity odd										
Si	Unit of measure 1=°C/K/barg   2=°F/psig	1	1	2	-	I	16	143	R/W	
IA	Enable operating mode modification 0/1 = yes/no	0	0	1	-	I	15	142	R/W	
U1	Enable manual valve positioning 0/1 = no/yes	0	0	1	-	D	11	10	R/W	
U2	Manual valve position	0	0	999	step	I	7	134	R/W	
U3	Valve control steps: 1/2 = 480/960 steps	1	1	2	-	I	11	138	R/W	
U4	Valve opening at start-up (evaporator/valve capacity ratio)	50	0	100	%	I	19	146	R/W	
Fr	Firmware version	1.3	-	-	-	A	9	8	R	
di	DI configuration	1	1	2	-	I	18	145	R/W	
	1=start/stop control 2=control backup									
rt	Reserved	1	1	1	-					
L1	Pressure S1: MINIMUM alarm value	-1	-85 (-121)	Pressure S1: MAX alarm value	barg (psig)	A	20	19	R/W	
H1	Pressure S1: MAXIMUM alarm value	9.3	Pressure S1: MIN alarm value	200 (392)	barg (psig)	A	21	20	R/W	

Tab. 7.a

## 8. NETWORK CONNECTION

The driver can be connected via a network connection to:

1. a computer running the VPM software, for setting the parameters before commissioning;
2. a pCO controller, loaded with the application program;
3. a PlantVisor/PlantVisorPRO supervisor, for remote monitoring and alarm detection.

### 8.1 RS485 serial configuration

n1 assigns to the controller an address for serial connection to a supervisory and/or telemaintenance system.

Par.	Description	Def.	Min.	Max.	UoM
n1	Network address	99	1	99	-
n2	Baud rate (bit/s)	2	0	17	-
0	4800, 2 stop bit, parity none				
1	9600, 2 stop bit, parity none				
2	19200, 2 stop bit, parity none				
3	4800, 1 stop bit, parity none				
4	9600, 1 stop bit, parity none				
5	19200, 1 stop bit, parity none				
6	4800, 2 stop bit, parity even				
7	9600, 2 stop bit, parity even				
8	19200, 2 stop bit, parity even				
9	4800, 1 stop bit, parity even				
10	9600, 1 stop bit, parity even				
11	19200, 1 stop bit, parity even				
12	4800, 2 stop bit, parity odd				
13	9600, 2 stop bit, parity odd				
14	19200, 2 stop bit, parity odd				
15	4800, 1 stop bit, parity odd				
16	9600, 1 stop bit, parity odd				
17	19200, 1 stop bit, parity odd				

**Important:** all controllers connected in a serial network need to be set with the same communication parameters.

### 8.2 Network connection for commissioning via PC

**Warnings:**

- fasten the converter properly so as to prevent disconnection;
- complete the wiring without power connected;
- keep the CVSTDUMORO interface cables separate from the power cables (power supply);
- in compliance with standards on electromagnetic compatibility, a shielded cable suitable for RS485 data transmission is used.

The RS485 converter is used to connect a computer running the VPM software to the EVD mini driver via a serial network, for commissioning the controllers. The system allows a maximum of 99 units, with a maximum network length of 500 m. Connection requires the standard accessories (RS485-USB converter, CAREL P/N CVSTDUMORO) and a 120 Ω terminating resistor to be installed on the terminals of the last connected controller. Connect the RS485 converter to controllers and make the connections as shown in the figure. To assign the serial address, see parameter n1. See the converter technical leaflets for further information.

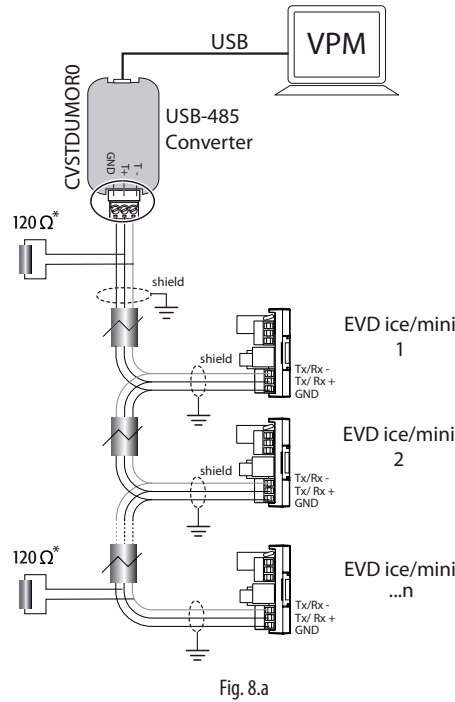

Fig. 8.a

### 8.3 Visual parameter manager

Go to <http://ksa.carel.com> and follow the instructions below. Select in sequence:

1. "Software & Support"
2. "Configuration & Updating Softwares"
3. "Parametric Controller Software"
4. "Visual Parametric Manager"

A window will open with the possibility to download two files:

1. VPM\_setup\_X.Y.Z.W\_full.zip: complete program;
2. X.Y.Z.W\_VPM\_Devices\_Upgrade.zip: upgrade for supported devices;

If this is the first installation, select Setup full, otherwise Upgrade. The program installs automatically by running setup.exe.

**Note:** if choosing complete installation (Setup full), uninstall any previous versions of VPM.

### Programming

When opening the program, the device to be configured needs to be selected: EVD mini. The Home page then opens, offering the choice between starting a new project or opening an existing project. If using the program for the first time, choose new project.

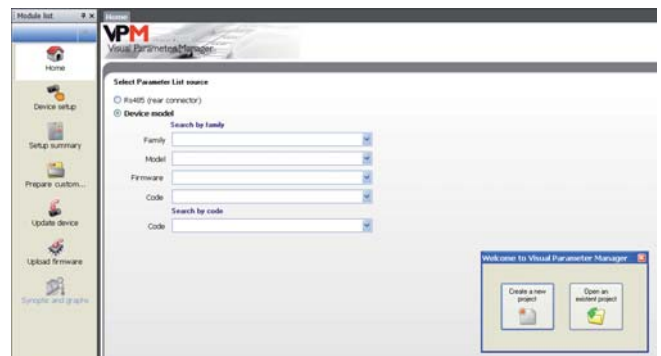

Fig. 8.b

The following options are then available:

1. Directly access the list of parameters saved in EEPROM: select "RS485";

The operations are performed in real time (ONLINE mode), at the top right set network address 99 and choose the guided procedure for USB port recognition, then go to "Device setup";

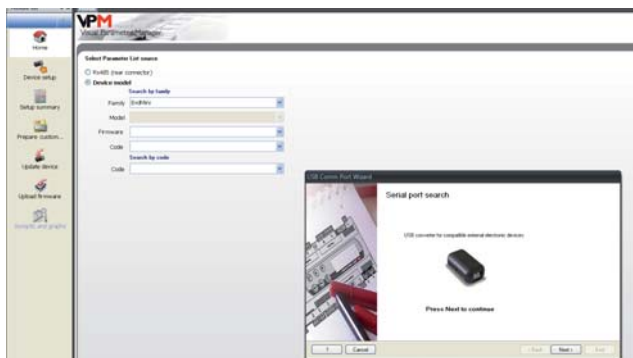

Fig. 8.c

2. Select the model from the range based on the firmware version and list of configuration parameters (EVDMINI0000E0X\_R\*). These operations are performed in OFFLINE mode.

**Menu**

The pages marked 1) can be accessed with Online or Offline, while those marked 2) are Online only.

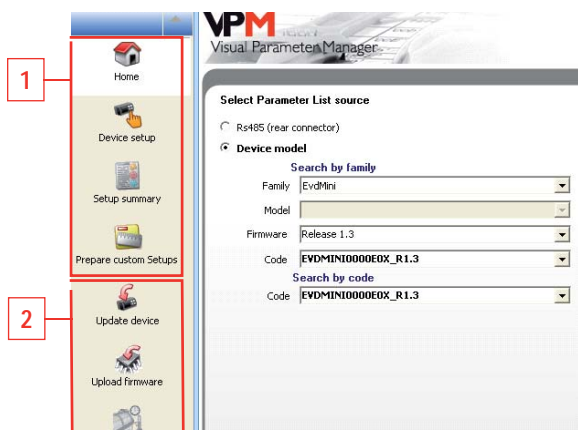

Fig. 8.d

The operations that can be performed on the pages marked 1) depend on the first selection made.

**Note:** to access the Online help press F1.

Ref.	Description	
Home	Select operating mode	Online → RS485 (rear connector) Offline → Device model
Device setup	Read instant values of control parameters	Online Offline Select Load to load a list of project parameters (.hex), modify and save a new project.
Setup summary	Display the default values for the current list of parameters	
Prepare custom setup	See online help.	
Update device	Select list of parameters and then Upload to controller	
Upload firmware	Select firmware and Upload	
Synoptic and graphs	Overview with position of probes and probe and superheat readings in real time	

Tab. 8.b

**8.4 Restore default parameters**

To restore the default parameter values on the controller:

1. Establish an RS485 serial connection between the computer and the driver. The LEDs on the USB/RS485 converter will flash;

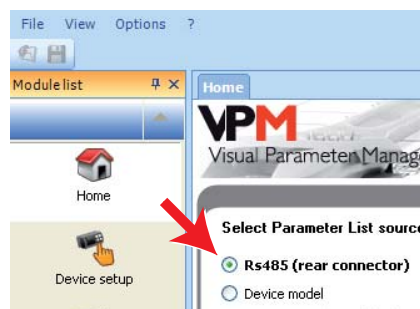

Fig. 8.e

2. Select "Update device" and:
  - a. Click button (A) to open the drop-down menu;
  - b. Select the list of parameters corresponding to the controller's firmware version: "EVDMINI\*\*\*.hex";
  - c. Click "Update" to load the parameters to the list and immediately after restore the controller parameters to the default value.

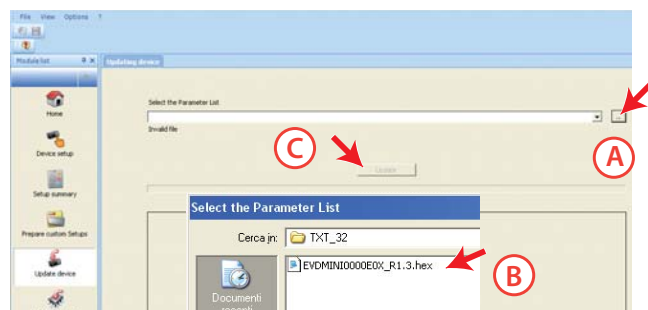

Fig. 8.f

3. Go to "Device setup": the program automatically reads the default parameters saved on the controller.

**8.5 Setup by direct copy**

1. On the Home page select RS485 (rear connector);



Fig. 8.g

2. Go to "Device setup";

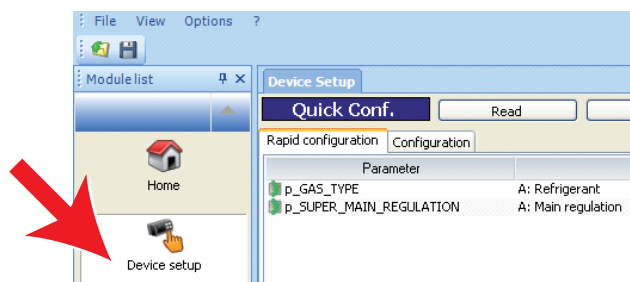

Fig. 8.h



- a. on the “Rapid configuration” page, set parameters “p\_GAS\_TYPE” = refrigerant and “p\_SUPER\_MAIN\_REGULATION” = type of control;

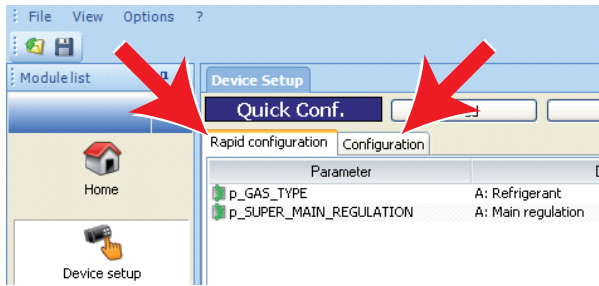

Fig. 8.i

- b. on the “Configuration” page, set parameter “p\_SH\_SET”.

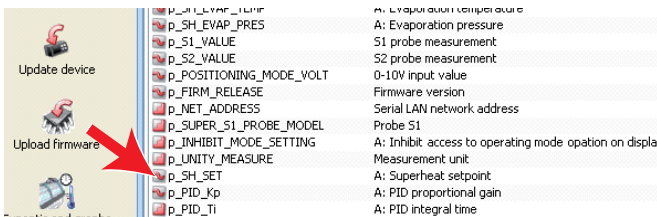

Fig. 8.j

3. Check whether there are other parameters that need to be set (see the “Functions” chapter);
4. Finally, select “Write” to copy the parameters to the controller.

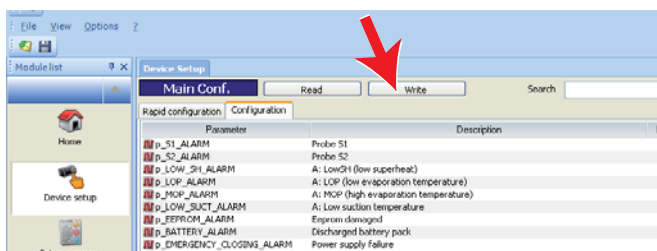

Fig. 8.k

## 8.6 Setup using configuration file

On the Home page select “Device model”.



Fig. 8.l

- The setup procedure comprises three steps:
1. Create the configuration file;
  2. Copy the configuration file to the controller;
  3. Read the configuration file on the controller.

## Create the configuration file

1. Select the “Device setup” page;
2. Set the parameters by double clicking, as shown in the figure:
  - a. on the “Rapid configuration” page, parameters “p\_GAS\_TYPE” = refrigerant and “p\_SUPER\_MAIN\_REGULATION” = type of control;
  - b. on the “Configuration” page, parameter “p\_SH\_SET”.

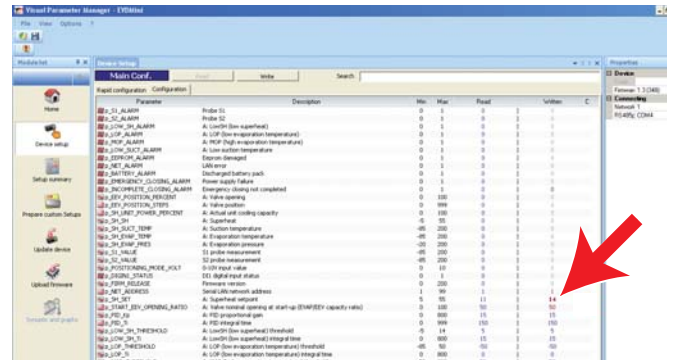
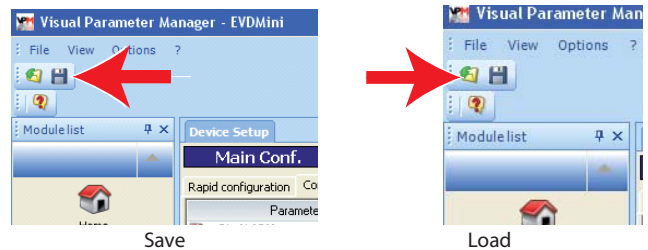

Fig. 8.m

3. Save the list of parameters with a new name, for example “NEW\_NAME.hex”. To load and display a list saved by the user, select “Load” and navigate to the path where the file is saved. On the other hand, to load a list of parameters supplied by CAREL, select “Load” and navigate the following path:

Load→Plugins→Commissioning EVD mini →TXT→TXT32.



## Copy the configuration file to the controller

Select “Update device” and:

- a. Click button (A) to open the drop-down menu;

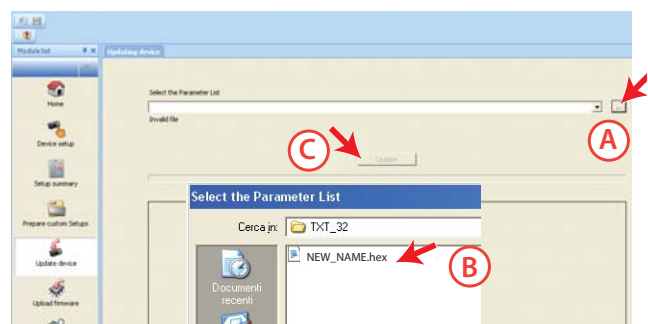

Fig. 8.n

- b. Select the list of parameters corresponding to the project file created: “NEW\_NAME.hex”;
- c. Click “Update” to UPLOAD the parameters to the controller.

## 8.7 Read the configuration file on the controller

1. Go to the “Home” page and select RS485 (rear connector);
2. Go to “Device setup” to read the list of parameters on the controller and make sure the settings are correct.

## 8.8 Variables accessible via serial connection

Parameter	Description	Def.	Min	Max	Type	Carel	Modbus®	R/W	Notes
Reg_status	Controller status	0	0	20	I	1	128	R	
Machine_type_SPV	Type of unit	0	0	32767	I	2	129	R	
Hardware_code_SPV	Hardware code	0	0	32767	I	3	130	R	
EEV_Positions_steps	Valve position	0	0	999	I	4	131	R	
Protection_status	Protection status	0	0	5	I	5	132	R	
Sh_unit_power_percent	Cooling capacity	0	0	100	I	6	133	R/W	
Man_posit_steps	Manual valve position	0	0	999	I	7	134	R/W	par. U2
Start_func_test	Input variable in functional test	0	0	30000	I	8	135	R/W	
Func_test_2	Generic variable to use in the functional test	0	-32768	32767	I	9	136	R/W	
Net_address	LAN serial network address	99	1	99	I	10	137	R/W	par. n1
EEV_steps_doubling	Double valve steps	1	1	2	I	11	138	R/W	par. U3
Gas_type	Refrigerant	3	1	23	I	12	139	R/W	Gas Type = refrigerant
Super_main_regulation	Main control	1	0	9	I	13	140	R/W	Mode = operating mode
Super_S1_probe_model	Probe S1	3	1	14	I	14	141	R/W	par. S1
Inhibit_mode_setting	Enable mode parameter setting	0	0	1	I	15	142	R/W	par. IA
Unity_measure	Unit of measure	1	1	2	I	16	143	R/W	par. Si
PID_Ti	PID: integral time	150	0	999	I	17	144	R/W	par. ti
Par_Digin1_Config	Digital input configuration 1=Start/stop control 2=Control backup	1	1	2	I	18	145	R/W	
Start_eev_opening_ratio	Valve position at start-up	50	0	100	I	19	146	R/W	par. U4
Net_setting	Baud rate	2	0	17	I	20	147	R/W	par. n2
Reset_Default(*)	Reset factory parameters	0	-32768	32767	I	21	148	R/W	
Ultracella_signature	Reserved	0	-32768	32767	I	22	149	R/W	
Regulation_type	Type of control	1	1	9	I	23	150	R	
Gas_custom_dew_a_h	Dew point a high	-288	-32768	32767	I	24	151	R/W	
Gas_custom_dew_a_l	Dew point a low	-15818	-32768	32767	I	25	152	R/W	
Gas_custom_dew_b_h	Dew point b high	-14829	-32768	32767	I	26	153	R/W	
Gas_custom_dew_b_l	Dew point b low	16804	-32768	32767	I	27	154	R/W	
Gas_custom_dew_c_h	Dew point c high	-11664	-32768	32767	I	28	155	R/W	
Gas_custom_dew_c_l	Dew point c low	16416	-32768	32767	I	29	156	R/W	
Gas_custom_dew_d_h	Dew point d high	-23322	-32768	32767	I	30	157	R/W	
Gas_custom_dew_d_l	Dew point d low	-16959	-32768	32767	I	31	158	R/W	
Gas_custom_dew_e_h	Dew point e high	-16378	-32768	32767	I	32	159	R/W	
Gas_custom_dew_e_l	Dew point e low	15910	-32768	32767	I	33	160	R/W	
Gas_custom_dew_f_h	Dew point f high	-2927	-32768	32767	I	34	161	R/W	
Gas_custom_dew_f_l	Dew point f low	-17239	-32768	32767	I	35	162	R/W	
Net_alarm	Network alarm	0	0	1	D	1	0	R	al. E6
Emergency_closing_alarm	No power supply	0	0	1	D	2	1	R	al. E5
S1_alarm	Probe S1 alarm	0	0	1	D	3	2	R	al. A1
S2_alarm	Probe S2 alarm	0	0	1	D	4	3	R	al. A2
Low_sh_alarm	Low_SH alarm	0	0	1	D	5	4	R	al. E3
LOP_alarm	LOP alarm	0	0	1	D	6	5	R	al. E2
MOP_alarm	MOP alarm	0	0	1	D	7	6	R	al. E1
Low_suct_alarm	Low suction temperature alarm	0	0	1	D	8	7	R	al. E4
Eeprom_alarm	EEPROM damaged	0	0	1	D	9	8	R	al. EE
Digin1_status	Digital input status	0	0	1	D	10	9	R	
Manual_posit_enable	Enable manual valve	0	0	1	D	11	10	R/W	par. U1
Incomplete_closing_alarm	Emergency closing not completed	0	0	1	D	12	11	R/W	al. E8
Battery_alarm	Battery alarm	0	0	1	D	13	12	R	
EVD_CAN_GO	Enable EVD control	0	0	1	D	14	13	R/W	
S1_Alarm_enable	Enable probe S1	0	0	1	D	15	14	R/W	
S2_Alarm_enable	Enable probe S2	0	0	1	D	16	15	R/W	
EEV_Position_percent	Valve opening	0	0	100	A	1	0	R	par. Po
SH_SH	Superheat	0	-5 (-9)	55 (99)	A	2	1	R	
Sh_Suct_temp	Suction temperature	0	-85(-121)	200(392)	A	3	2	R	par. t5
Sh_Evap_temp	Evaporation temperature	0	-85(-121)	200(392)	A	4	3	R	
Sh_Evap_pres	Evaporation pressure	0	-20(-290)	200(2900)	A	5	4	R	
S1_Value	Probe S1 reading	0	-85(-290)	200(2900)	A	6	5	R	par. P1
S2_Value	Probe S2 reading	0	-85(-121)	200(392)	A	7	6	R	par. P2
Positioning_mode_volt	0-10 V input	0	0	10	A	8	7	R	
Firm_release	Firmware version	0	0	800	A	9	8	R	par. Fr
SH_Set	Superheat set point	11	Low_ Sh_Th- reshold	55(99)	A	10	9	R/W	Super heat = superheat set point
PID_Kp	PID: proportional gain	15	0	800	A	11	10	R/W	par. CP
Low_sh_threshold	Low superheat: threshold	5	-5(-9)	Set point surrisc.	A	12	11	R/W	par. C1
Low_sh_Ti	Low superheat: integral time	15	0	800	A	13	12	R/W	par. C2
Lop_threshold	LOP: threshold	-50(-58)	-85(-121)	MOP_th- reshold	A	14	13	R/W	par. C3
Lop_Ti	LOP: integral time	0	0	800	A	15	14	R/W	par. C4
MOP_Threshold	MOP: threshold	50	LOP_th- reshold	200 (392)	A	16	15	R/W	par. C5
MOP_Ti	MOP: integral time	20	0	800	A	17	16	R/W	par. C6
Low_Suct_alarm_threshold	Low suction temperature alarm threshold	-50(-58)	-85(-121)	200(392)	A	18	17	R/W	par. C8
Mop_Inhibition_threshold	MOP: inhibition threshold	30 (86)	-85 (-121)	200 (392)	A	19	18	R/W	

Parameter	Description	Def.	Min	Max	Type	Carel	Modbus*	R/W	Notes
S1_Alarm_threshold_low	Pressure S1: MINIMUM alarm value	-1	-85(-290)	Par_S1_Alarm_threshold_high	A	20	19	R/W	
S1_Alarm_threshold_high	Pressure S1: MAXIMUM alarm value	9,3	Par_S1_Alarm_threshold_low	200(2900)	A	21	20	R/W	
TCTRL_REV_SET	Hot gas bypass temperature set point	10	-85 (-121)	200 (392)	A	22	21	R/W	par._t
PCTRL_REV_SET	Hot gas bypass pressure set point	3	-20 (-290)	200 (2900)	A	23	22	R/W	par._P
SH_actual_set	Reserved	0	-40(-72)	180(324)	A	24	23	R	
SH_Set_smooth_line	Superheat set point offset for smooth lines	0	-55(-99)	55(99)	A	25	24	R/W	
S1_value_remote	S1 probe reading from supervisor	0	-20(-290)	200(2900)	A	26	25	R/W	

(\*) set to 1973 to reset the parameters to the default values

Tab. 8.c

## 8.9 Control states

The electronic valve controller can have six different control states, each of which may correspond to a specific phase in the operation of the refrigeration unit and a certain status of the driver-valve system. The states are as follows:

- forced closing: initialisation of the valve position when switching the instrument on;
- standby: no temperature control, unit OFF (at temp.);
- wait: opening of the valve before starting control, also called pre-positioning, when powering the unit on;
- control: effective control of the electronic valve, unit ON;
- positioning: step-change in the valve position, corresponding to the start of control when the cooling capacity of the controlled unit varies (only EVD connected to a pCO);
- stop: of control with closing of the valve, corresponds to the end of temperature control of the refrigeration unit, unit OFF (at temp.).

### Forced closing

Forced closing is performed after the driver is powered on and corresponds to the typical number of closing steps for CAREL E2V and E3V unipolar valves. This is used to realign the valve to the physical position corresponding to completely closed. The driver and the valve are then ready for control and both aligned at 0 (zero). At power-on, first a forced closing is performed, and then the standby phase starts. The valve is also closed in the event of a mains power failure if the Ultracap module is connected. In this case, the "Forced valve closing not completed" parameter is set to 1. On restarting, if the valve forced closing procedure is not completed successfully:

1. the Master programmable controller (pCO) will check the value of the parameter, and if equal to 1 will decide the best strategy to adopt, based on the application;
2. on restarting the driver positions the valve as explained in the paragraph "Pre-positioning/start control". The parameter is set to 0 (zero) by the Master controller (e.g. pCO), or alternatively by pressing the PRG/Set button on the keypad. Once the parameter has been set to 1, the driver sets it back to 0 (zero) only if an emergency forced closing procedure is completed successfully.

 **Note:** the user can only select the resolution of the valve control signal: 480 or 960 steps.

Par.	Description	Def.	Min.	Max.	UoM
U3	Valve control steps 1 / 2 = 480/ 960 steps	1	1	2	-

### Standby

Standby corresponds to a situation of rest in which no signals are received to control the electronic valve: it is closed and manual positioning can be activated. This status is normally set on the driver when the refrigeration unit is shutdown manually (e.g. from the supervisor) or when reaching the control set point. It can also occur when opening the digital input (which involves closing the valve) or in the event of a probe alarm. In general, it can be said that the electronic valve driver is in standby when the compressor stops or the control solenoid valve closes.

### Pre-positioning/start control

If during standby a control request is received, before starting control the valve is moved to a precise initial position. Internally, the pre-positioning time is set at 6 s and represents the time that the valve is held in a fixed position. By default the valve is opened 50 % when starting (from digital input), so as to minimise the movement needed to reach the correct position.

Par.	Description	Def.	Min.	Max.	UoM
U4	Valve opening at start-up	50	0	100	%

This parameter should be set based on the ratio between the rated cooling capacity of the evaporator and the valve (e.g. rated evaporator cooling capacity: 3kW, rated valve cooling capacity: 10kW, valve opening = 3/10 = 33%).

The driver calculates the valve opening based on the required capacity:

**If required capacity is 100%:**

Opening (%)= (Valve opening at start-up);

**If required capacity is less than 100% (capacity control):**

Opening (%)= (Valve opening at start-up) x (Current unit cooling capacity), where the current unit cooling capacity is sent to the driver via RS485 by the pCO controller. If the driver is stand-alone, this is always equal to 100%.

### Notes:

- this procedure is used to anticipate the movement and bring the valve significantly closer to the operating position in the phases immediately after the unit is powered on;
- if there are problems with liquid return after the refrigeration unit starts or in units that frequently switch on-off, the valve opening at start-up must be decreased. If there are problems with low pressure after the refrigeration unit starts, the valve opening must be increased.

### Wait

When the calculated position has been reached, regardless of the time taken (this varies according to the type of valve and the objective position), there is a constant 5 second delay before the actual control phase starts. This is to create a reasonable interval between standby, in which the variables have no meaning, as there is no flow of refrigerant, and the effective control phase.

### Control

The control request can be received by the closing of the digital input or via network (RS485). The solenoid or the compressor are activated when the valve, following the pre-positioning procedure, has reached the calculated position. The following figure represents the sequence of events for starting control of the refrigeration unit.

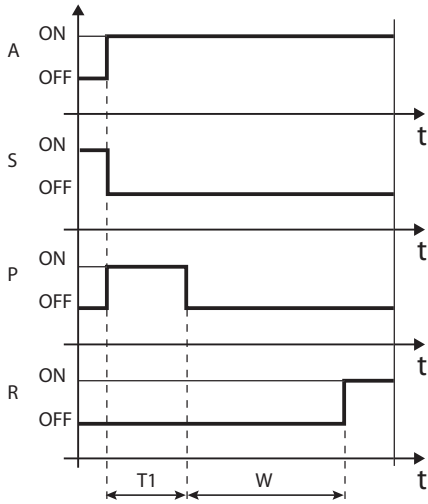

Fig. 8.o

Key:

A	Control request	T1	Pre-positioning time
P	Pre-positioning	W	Wait (wait)
S	Standby	t	Time
R	Control		

**Positioning (change cooling capacity)**

This control status is only valid for controllers connected to the pCO via RS485. If there is a change in unit cooling capacity of at least 10%, sent from the pCO via RS485, the valve is positioned proportionally. In practice, this involves repositioning starting from the current position in proportion to how much the cooling capacity of the unit has increased or decreased in percentage terms. When the calculated position has been reached, regardless of the time taken, there is a constant 5 second delay before the actual control phase starts.

**Note:** if information is not available on the variation in unit cooling capacity, this will always be considered as operating at 100% and therefore the procedure will never be used. In this case, the PID control must be more reactive (see the chapter on Control) so as to react promptly to variations in load that are not communicated to the driver.

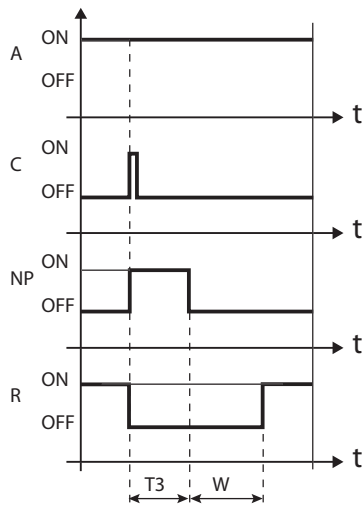

Fig. 8.p

Key:

A	Control request	R	Control
C	Change in capacity	T3	Repositioning time
NP	Repositioning	t	Time
W	Wait		

**Stop/end control**

The stop procedure involves closing the valve from the current position until reaching 0 steps, plus a further number of steps so as to guarantee complete closing. Following the stop phase, the valve returns to standby.

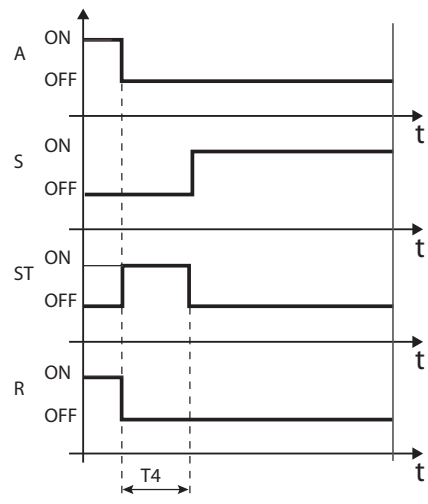

Fig. 8.q

Key:

A	Control request	R	Control
S	Standby	T4	Stop position time
ST	Stop	t	Time

**8.10 Special control states**

As well as normal control status, the driver can have three special states related to specific functions:

- manual positioning: this is used to interrupt control so as to move the valve, setting the desired position;
- recover physical valve position: recover physical valve steps when fully opened or closed;
- unblock valve: forced valve movement if the driver considers it to be blocked.

**Manual positioning**

Manual positioning can be activated at any time during the standby or control phase. Manual positioning, once enabled, is used to freely set the position of the valve using the corresponding parameter.

Control is placed on hold, all the system and control alarms are enabled, however neither control nor the protectors can be activated. Manual positioning thus has priority over any driver state/protector.

Par.	Description	Def.	Min.	Max.	UoM
U1	Enable manual valve positioning: 0/1=yes/no	0	0	1	-
U2	Manual valve position	0	0	999	step

**Notes:**

1. the manual positioning status is NOT saved when restarting after a power failure.
2. in for any reason the valve needs to be kept stationary after a power failure, proceed as follows:
  - remove the valve stator;
  - set the PID proportional gain =0. The valve will remain stopped at the initial opening position, set by corresponding parameter

### Retrieve physical valve position

This procedure is necessary as the stepper motor intrinsically tends to lose steps during movement. Given that the control phase may last continuously for several hours, it is probable that from a certain time on the estimated position sent by the valve driver does not correspond exactly to the physical position of the movable element. This means that when the driver reaches the estimated fully closed or fully open position, the valve may physically not be in that position. The "Synchronisation" procedure allows the driver to perform a certain number of steps in the suitable direction to realign the valve.



**Note:** realignment is in intrinsic part of the forced closing procedure and is activated whenever the driver is stopped/started and in the standby phase.

### Unblock valve

This procedure is only valid when the driver is performing superheat control. Unblock valve is an automatic safety procedure that attempts to unblock a valve that is supposedly blocked based on the control variables (superheat, valve position). The unblock procedure may or may not succeed depending on the extent of the mechanical problem with the valve. If for 10 minutes the conditions are such as to assume the valve is blocked, the procedure is run a maximum of 5 times. The symptoms of a blocked valve do not necessarily mean a mechanical blockage. They may also represent other situations:

- mechanical blockage of the solenoid valve upstream of the electronic valve (if installed);
- electrical damage to the solenoid valve upstream of the electronic valve;
- blockage of the filter upstream of the electronic valve (if installed);
- electrical problems with the electronic valve motor;
- electrical problems in the driver-valve connection cables;
- incorrect driver-valve electrical connection;
- incorrect driver-valve electrical connection;
- electronic problems with the valve control driver;
- secondary fluid evaporator fan/pump malfunction;
- insufficient refrigerant in the refrigerant circuit;
- refrigerant leaks;
- lack of subcooling in the condenser;
- electrical/mechanical problems with the compressor;
- processing residues or moisture in the refrigerant circuit.



**Note:** the valve unblock procedure is nonetheless performed in each of these cases, given that it does not cause mechanical or control problems. Therefore, also check these possible causes before replacing the valve.

## 9. ALARMS

### 9.1 Types of alarms

There are two types of alarms:

- system: EEPROM, probe and communication;
- control: low superheat, LOP, MOP, low suction temperature.

The activation of the alarms depends on the setting of the threshold and activation delay parameters. The EEPROM unit parameters and operating parameters alarm always shuts down the controller and cannot be reset. All the alarms are reset automatically, once the causes are no longer present, except for the "Emergency closing not completed" alarm, which requires manual reset.

**Example 1:** the board without display has the red ① flashing when an alarm is active. For EEPROM alarms, it stays on steady.

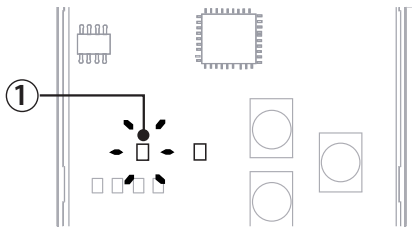

Fig. 9.a

### 9.2 Probe alarms

The probe alarms are part of the system alarms. When the value measured by one of the probes is outside of the range of measurement, an alarm is activated. The alarm limits correspond to the range of measurement.

In the event of a probe alarm, the driver closes the valve, regardless of digital input status, until the error is no longer present.

**Example:** the display shows probe alarms A1 and A2 in sequence. The superheat value has exceeded the maximum limit allowed, and this is indicated by the two top segments.

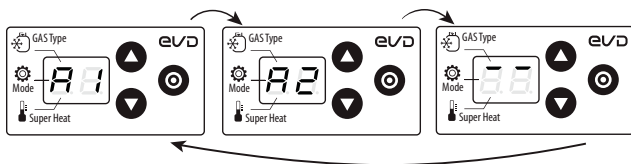

Fig. 9.b

#### Minimum and maximum superheat limits

If a probe alarm occurs, it may be due to the superheat value exceeding the allowed display range -5...55 K (-9 to 99°F). The display therefore shows the probe alarm code (A1/A2) and:

1. if the superheat value is less than -5K, the display shows the two bottom segments;
2. if the superheat value is higher than 55K, the display shows the two top segments.

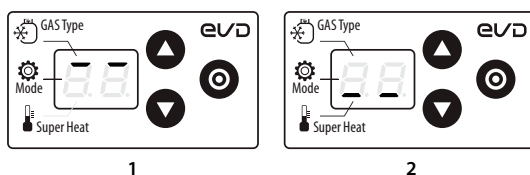

Fig. 9.c

### 9.3 Control alarms

These are alarms that are only activated during control.

#### Protector alarms

The alarms corresponding to the LowSH, LOP and MOP protectors are only activated during control when the corresponding activation threshold is exceeded, and only when the delay time defined by the corresponding parameter has elapsed. If a protector is not enabled (integral time= 0 s), no alarm will be signalled. If before the expiry of the delay, the protector control variable returns back inside the corresponding threshold, no alarm will be signalled.

**Note:** this is a likely event, as during the delay, the protection function will have an effect.

#### Low suction temperature alarm

The low suction temperature alarm is not linked to any protection function. It features a threshold and a fixed delay (300 seconds), and is useful in the event of probe or valve malfunctions to protect the compressor using the relay to control the solenoid valve or to simply signal a possible risk. In fact, incorrect measurement of the evaporation pressure or incorrect configuration of the type of refrigerant may mean the superheat calculated is much higher than the actual value, causing an incorrect and excessive opening of the valve. A low suction temperature measurement may in this case indicate probable flooding of the compressor, with corresponding alarm signal. The alarm is reset automatically, with a fixed differential of 3°C above the activation threshold.

Par.	Description	Def.	Min.	Max.	UoM
C8	Low suction temperature alarm threshold	-50 (-58)	-85 (-121)	200 (392)	°C(°F)

### 9.4 Valve emergency closing procedure

The following description only applies if EVD mini is connected to the Ultracap module.

In the event of a power failure, EVD mini can provide emergency closing of the valve, thus preventing any refrigerant from flowing to the compressor.

In this situation, the driver generates two alarms: E8 and E5. If the procedure concludes successfully (the valve closes completely), alarm E8 is cleared, however alarm E5 continues until the Ultracap module is able to power on the driver.

- E8: failed emergency closing (incomplete closing alarm). Active during the emergency closing stage and until the valve closes completely, after which alarm E8 is cleared. If the closing procedure is not completed (e.g. because the Ultracap module does not have enough charge), when next restarting the controller, the user must manually reset the alarm (pressing the PRG/SET button or setting the corresponding parameter to zero via serial connection);
- E5: emergency closing (emergency force closing alarm). This depends on a controller power failure and indicates that the emergency procedure is in progress.

**Notes:**

- if the voltage measured falls below a certain threshold, the controller, connected to the Ultracap module, can start the valve emergency closing procedure;
- during the valve emergency closing procedure, the display is switched off to save energy (therefore the alarms may not be shown on the display, or only shown for a brief instant);
- if power returns during the closing procedure, alarms E8 and E5 are reset and closing is completed in any case.

## 9.5 Network alarm

The digital input configuration parameter can only be set to control backup from the supervisor. If there is a communication error between the pCO controller and driver, the digital input status determines whether to continue control (input closed = the valve remains in the current position) or stop (input open).

## 9.6 Alarm table

Alarm code on the display	Red LED	Cause of the alarm	Reset	Effects on control	Checks / Solutions
A1	flashes	Probe S1 faulty or set alarm range exceeded	automatic	Valve closed	Check the probe connections.
A2	flashes	Probe S2 faulty or set alarm range exceeded	automatic	Valve closed	Check the probe connections.
E1	flashes	MOP protection activated	automatic	Protection action already in progress	Check parameter "MOP protection: threshold"
E2	flashes	LOP protection activated	automatic	Protection action already in progress	Check parameter "LOP protection: threshold"
E3	flashes	LowSH protection activated	automatic	Protection action already in progress	Check parameter "LowSH protection: threshold"
E4	flashes	Low suction temperature	automatic	No effect	Check the threshold parameter.
E5	flashes	Chiusura di emergenza: LowSH, LOP, MOP, bassa T/P di aspirazione, mancanza di alimentazione	automatic	Valve closed	Reset power supply
E6	flashes	Network error	automatic	Control based on DI	Check the wiring and that the pCO is on and operating
E7	flashes	Ultracap module powered at low voltage or low charge	automatic	No effect	Check the wiring, the power supply and that the minimum recharge time has elapsed
E8	flashes	Emergency closing not completed	Manual	Valve closed	Press PRG/Set or set the corresponding supervisor variable to 0
EE	on steady	EEPROM operating and/or unit parameters damaged	Replace the driver/ Contact service	Total shutdown	Replace the driver/Contact service

Tab. 9.d

## 10. TROUBLESHOOTING

The following table lists a series of possible malfunctions that may occur when starting and operating the driver and the electronic valve. These cover the most common problems and are provided with the aim of offering an initial response for resolving the problem.

PROBLEM	CAUSE	SOLUTION
The superheat value measured is incorrect	The probe does not measure correct values	Check that the pressure and the temperature measured are correct and that the probe position is correct. Make sure the correct pressure probe has been set. Check the correct probe electrical connections.
	The type of refrigerant set is incorrect	Check and correct the type of refrigerant parameter.
Liquid returns to the compressor during control	The superheat set point is too low	Increase the superheat set point. Initially set it to 11 K and check that there is no longer return of liquid. Then gradually reduce the set point, always making sure there is no return of liquid.
	Low superheat protection ineffective	If the superheat remains low for too long with the valve that is slow to close, increase the low superheat threshold and/or decrease the low superheat integration time. Initially set the threshold 3 °C below the superheat set point, with an integration time of 3-4 seconds. Then gradually lower the low superheat threshold and increase the low superheat integration time, checking that there is no return of liquid in any operating conditions.
	Stator broken or connected incorrectly	Disconnect the stator from the valve and the cable and measure the resistance of the windings using an ordinary tester. The resistance of both should be around 40 ohms. Otherwise replace the stator.
	Valve stuck open	Check if the superheating is always low (<2 °C) with the valve position permanently at 0 steps. If so, set the valve to manual control and close it completely. If the superheat is always low, check the electrical connections and/or replace the valve.
	The "valve opening at start-up" parameter is too high on many cabinets in which the control set point is often reached (for multiplexed cabinets only)	Decrease the value of the "Valve opening at start-up" parameter on all the utilities, making sure that there are no repercussions on the control temperature.
Liquid returns to the compressor only after defrosting (for multiplexed cabinets only)	The superheat temperature measured by the driver after defrosting and before reaching operating conditions is very low for a few minutes	Check that the LowSH threshold is greater than the superheat value measured and that the corresponding protection is activated (integration time >0 s). If necessary, decrease the value of the integration time.
	The superheat temperature measured by the driver does not reach low values, but there is still return of liquid to the compressor rack	Set more reactive parameters to bring forward the closing of the valve: increase the proportional factor to 30, increase the integration time to 250 s.
	Many cabinets defrosting at the same time	Stagger the start defrost times. If this is not possible, if the conditions in the previous two points are not present, increase the superheat set point and the LowSH thresholds by at least 2 °C on the cabinets involved.
	The valve is significantly oversized	Replace the valve with a smaller equivalent.
Liquid returns to the compressor only when starting the controller (after being OFF)	The "valve opening at start-up" parameter is set too high	Check the calculation in reference to the ratio between the rated cooling capacity of the evaporator and the capacity of the valve; if necessary, lower the value.
The superheat value swings around the set point with an amplitude greater than 4°C	The condensing pressure swings	Check the controller condenser settings, giving the parameters "blander" values (e.g. increase the proportional band or increase the integration time). Note: the required stability involves a variation within +/- 0.5 bars. If this is not effective or the settings cannot be changed, adopt electronic valve control parameters for perturbed systems
	The superheat swings even with the valve set in manual control (in the position corresponding to the average of the working values)	Check for the causes of the swings (e.g. low refrigerant charge) and resolve where possible.
	The superheat does NOT swing with the valve set in manual control (in the position corresponding to the average of the working values)	As a first approach, decrease (by 30 to 50 %) the proportional factor. Subsequently try increasing the integration time by the same percentage. In any case, adopt parameter settings recommended for stable systems.
	The superheat set point is too low	Increase the superheat set point and check that the swings are reduced or disappear. Initially set 13 °C, then gradually reduce the set point, making sure the system does not start swinging again and that the unit temperature reaches the control set point.
In the start-up phase with high evaporator temperatures, the evaporation pressure is high	MOP protection disabled or ineffective	Activate the MOP protection by setting the threshold to the required saturated evaporation temperature (high evaporation temperature limit for the compressors) and setting the MOP integration time to a value above 0 (recommended 4 seconds). To make the protection more reactive, decrease the MOP integration time.
	Refrigerant charge excessive for the system or extreme transitory conditions at start-up (for cabinets only).	Apply a "soft start" technique, activating the utilities one at a time or in small groups. If this is not possible, decrease the values of the MOP thresholds on all the utilities.



PROBLEM	CAUSE	SOLUTION
In the start-up phase the low pressure protection is activated (only for self-contained units)	The "Valve opening at start-up" parameter is set too low	Check the calculation in reference to the ratio between the rated cooling capacity of the evaporator and the capacity of the valve; if necessary lower the value.
	The driver in RS485 network does not start control and the valve remains closed	Check the serial connection. Check that the pCO application connected to the driver (where featured) correctly manages the driver start signal. Check that the driver is NOT in stand-alone mode.
	The driver in stand-alone configuration does not start control and the valve remains closed	Check the connection of the digital input. Check that when the control signal is sent that the input is closed correctly. Check that the driver is in stand-alone mode.
	LOP protection disabled	Set a LOP integration time greater than 0 s.
	LOP protection ineffective	Make sure that the LOP protection threshold is at the required saturated evaporation temperature (between the rated evaporation temperature of the unit and the corresponding temperature at the calibration of the low pressure switch) and decrease the value of the LOP integration time.
	Solenoid blocked	Check that the solenoid opens correctly, check the electrical connections.
	Insufficient refrigerant	Check that there are no bubbles in the sight glass upstream of the expansion valve. Check that the subcooling is suitable (greater than 5 °C); otherwise charge the circuit.
	The valve is connected incorrectly (rotates in reverse) and is open	Check the movement of the valve by placing it in manual control and closing or opening it completely. One complete opening must bring a decrease in the superheat and vice-versa. If the movement is reversed, check the electrical connections.
	Stator broken or connected incorrectly	Disconnect the stator from the valve and the cable and measure the resistance of the windings using an ordinary tester. The resistance of both should be around 40 ohms. Otherwise replace the stator.
Valve stuck closed	Use manual control after start-up to completely open the valve. If the superheat remains high, check the electrical connections and/or replace the valve.	
The unit switches off due to low pressure during control (only for self-contained units)	LOP protection disabled	Set a LOP integration time greater than 0 s.
	LOP protection ineffective	Make sure that the LOP protection threshold is at the required saturated evaporation temperature (between the rated evaporation temperature of the unit and the corresponding temperature at the calibration of the low pressure switch) and decrease the value of the LOP integration time.
	Solenoid blocked	Check that the solenoid opens correctly, check the electrical connections and the operation of the control relay.
	Insufficient refrigerant	Check that there are no bubbles of air in the liquid indicator upstream of the expansion valve. Check that the subcooling is suitable (greater than 5 °C); otherwise charge the circuit.
	The valve is significantly undersized	Replace the valve with a larger equivalent.
	Stator broken or connected incorrectly	Disconnect the stator from the valve and the cable and measure the resistance of the windings using an ordinary tester. The resistance of both should be around 40 ohms. Otherwise replace the stator.
Valve stuck closed	Use manual control after start-up to completely open the valve. If the superheat remains high, replace the valve body.	
The cabinet does not reach the set temperature, despite the valve being opened to the maximum (for multiplexed cabinets only)	Solenoid blocked	Check that the solenoid opens correctly, check the electrical connections and the operation of the relay.
	Insufficient refrigerant	Check that there are no bubbles of air in the liquid indicator upstream of the expansion valve. Check that the subcooling is suitable (greater than 5 °C); otherwise charge the circuit.
	The valve is significantly undersized	Replace the valve with a larger equivalent.
	Stator broken or connected incorrectly	Disconnect the stator from the valve and the cable and measure the resistance of the windings using an ordinary tester. The resistance of both should be around 40 Ω. Otherwise replace the stator.
	Valve stuck closed	Use manual control after start-up to completely open the valve. If the superheat remains high, replace the valve body.
The cabinet does not reach the set temperature, and the position of the valve is always 0 (for multiplexed cabinets only)	The driver in RS485 network does not start control and the valve remains closed	Check the network connections. Check that the pCO application connected to the driver (where featured) correctly manages the driver start signal. Check that the driver is NOT in stand-alone mode.
	The driver in stand-alone configuration does not start control and the valve remains closed	Check the connection of the digital input. Check that when the control signal is sent that the input is closed correctly. Check that the driver is in stand-alone mode.

## 11. TECHNICAL SPECIFICATIONS

	EVD mini (24 V)	EVD mini (230 V)
Power supply	1. 24 Vac (+10/-15%) 50/60 Hz. • Use a class II isolating transformer (min 20VA, max 50VA) • Length of connection between transformer and EVDmini Lmax=1 m 2. 24 Vdc (+10/-15%) • Use an external 24 Vdc power supply, min 15 W	115...230 Vac (+10/-15%) 50/60 Hz • Length of power supply cable: Lmax=1 m.
Max power consumption (W)	13	15
Emergency power supply	13 Vdc +/-10% (If the optional Ultracap module for EVD mini is installed)	
Driver	Unipolar valve	
<b>Connections:</b>		
Motor connection	6-wire cable type AWG 18/22, Lmax=1m (see NOTE)	
Digital inputs connection	Digital input to be activated from voltage-free contact or transistor to GND. Closing current: 5mA. Maximum contact resistance: <50Ω Lmax=10 m for residential/industrial, 2 m for domestic environments	Digital input 230 Vac optoisolated Closing current: 10 mA
Probes	Lmax=10 m for residential/industrial, 2 m for domestic environments	
S1	Low temperature NTC:	10 kΩ a 25°C, -50T90°C Measurement error: 1°C in the range -50T50°C; 3°C in the range +50T90°C
	Ratiometric pressure probe (0...5V)	Resolution 0,1 % fs Measurement error: 2% fs maximum; 1% typical
S2	Low temperature NTC:	10kΩ a 25°C, -50T90°C Measurement error: 1°C in the range -50T50°C; 3°C in the range +50T90°C
	Input 0...10V (max 12V)	Resolution 0,1 % fs Measurement error: 9% fs maximum; 8% typical
Power to active probes (V REF)	+5Vdc+/-2%	
RS485 serial connection	Modbus, Lmax=500 m, shielded cable, earth both ends of the cable shield	
Assembly	on DIN rail or with screws	on DIN rail
Connectors	wire size 0,35...2,5 mm <sup>2</sup> (12...22 AWG)	
Dimensions	Base x height x depth = 88 x 90 x 33 mm	Base x height x depth = 70,4 x 114 x 38 mm
Operating conditions	-25T60°C; <90% U.R. non-condensing	
Storage conditions	-35T60°C, <90% U.R. non-condensing	
Index protection	IP00	
Environmental pollution	2	
Resistance to heat and fire	Category D	
Overvoltage category	Category II	
Insulation class	III	II
Class and software structure	A	
<b>Conformity</b>		
Electrical safety	EN 60730-1, UL 60730-1, UL 60730-2-9	
Electromagnetic compatibility	EN 61000-6-1, EN 61000-6-2, EN 61000-6-3, EN 61000-6-4 EN61000-3-2, EN55014-1, EN61000-3-3	

 **Note:** if using in domestic and/or residential environments (EN55014-1/EN61000-6-3) with the controller not installed inside a metallic panel, fit the ferrite (P/N 0907879AXX):

- for EVD mini 24 V: applied on the valve stator cable if using in domestic/residential environments with valve cable > 0.5 m;
- for EVD mini 115/ 230 V: applied on the valve stator cable if using in domestic/residential environments with valve cable > 0.4 m.



# CAREL

**CAREL INDUSTRIES HeadQuarters**

Via dell'Industria, 11 - 35020 Brugine - Padova (Italy)

Tel. (+39) 049.9716611 - Fax (+39) 049.9716600

e-mail: [carel@carel.com](mailto:carel@carel.com) - [www.carel.com](http://www.carel.com)

*Agenzia / Agency:*