

EVD⁴

Driver for electronic expansion valve

CAREL



ENG User manual

User manual



**We wish to save you time and money!
We can assure you that the thorough reading
of this manual will guarantee correct
installation and safe use of the product
described.**

INFORMATION FOR USERS ON THE CORRECT HANDLING OF WASTE ELECTRICAL AND ELECTRONIC EQUIPMENT (WEEE)



In reference to European Community directive 2002/96/EC issued on 27 January 2003 and the related national legislation, please note that:

1. WEEE cannot be disposed of as municipal waste and such waste must be collected and disposed of separately;
2. the public or private waste collection systems defined by local legislation must be used. In addition, the equipment can be returned to the distributor at the end of its working life when buying new equipment.
3. the equipment may contain hazardous substances: the improper use or incorrect disposal of such may have negative effects on human health and on the environment;
4. the symbol (crossed-out wheeled bin) shown on the product or on the packaging and on the instruction sheet indicates that the equipment has been introduced onto the market after 13 August 2005 and that it must be disposed of separately;
5. in the event of illegal disposal of electrical and electronic waste, the penalties are specified by local waste disposal legislation.

IMPORTANT WARNINGS



CAREL bases the development of its products on several years' experience in the HVAC field, on continuous investment in technological innovation of the product, on rigorous quality procedures and processes with in-circuit and function tests on 100% of its production, on the most innovative production technologies available on the market. CAREL and its branch offices/affiliates do not guarantee, in any case, that all the aspects of the product and the software included in the product will respond to the demands of the final application, even if the product is built according to state-of-the-art techniques. The client (builder, developer or installer of the final equipment) assumes every responsibility and risk relating to the configuration of the product in order to reach the expected results in relation to the specific final installation and/or equipment. CAREL in this case, through specific agreements, can intervene as consultant for the positive result of the final start-up machine/application, but in no case can it be held responsible for the positive working of the final equipment/apparatus.

The CAREL product is a state-of-the-art product, whose operation is specified in the technical documentation supplied with the product or can be downloaded, even prior to purchase, from the website www.carel.com.

Each CAREL product, in relation to its advanced technological level, needs a phase of definition/ configuration / programming / commissioning so that it can function at its best for the specific application. The lack of such phase of study, as indicated in the manual, can cause the final product to malfunction of which CAREL can not be held responsible.

Only qualified personnel can install or carry out technical assistance interventions on the product. The final client must use the product only in the manner described in the documentation related to the product itself.

Without excluding proper compliance with further warnings present in the manual, it is stressed that in any case it is necessary, for each Product of CAREL:

- To avoid getting the electrical circuits wet. Rain, humidity and all types of liquids or condensation contain corrosive mineral substances that can damage the electrical circuits. In any case, the product should be used and stored in environments that respect the range of temperature and humidity specified in the manual.
- Do not install the device in a particularly hot environment. Temperatures that are too high can shorten the duration of the electronic devices, damaging them and distorting or melting the parts in plastic. In any case, the product should be used and stored in environments that respect the range of temperature and humidity specified in the manual.
- Do not try to open the device in any way different than that indicated in the manual.
- Do not drop, hit or shake the device, because the internal circuits and mechanisms could suffer irreparable damage.
- Do not use corrosive chemical products, aggressive solvents or detergents to clean the device.
- Do not use the product in application environments different than those specified in the technical manual.

All the above reported suggestions are valid also for the control, serial unit, programming key or nevertheless for any other accessory in the product portfolio of CAREL. CAREL adopts a policy of continuous development. Therefore, CAREL reserves the right to carry out modifications and improvements on any product described in the present document without prior notice. The technical data in the manual can undergo modifications without obligation to notice. The liability of CAREL in relation to its own product is regulated by CAREL's general contract conditions edited on the website www.carel.com and/or by specific agreements with clients; in particular, within the criteria consented by the applicable norm, in no way will CAREL, its employees or its branch offices/affiliates be responsible for possible lack of earnings or sales, loss of data and information, cost of substitute goods or services, damage to things or persons, work interruptions, or possible direct, indirect, incidental, patrimonial, of coverage, punitive, special or consequential in any way caused damages, be they contractual, out-of-contract, or due to negligence or other responsibility originating from the installation, use or inability of use of the product, even if CAREL or its branch offices/affiliates have been warned of the possibility of damage.

Content

1. INTRODUCTION	7
1.1 Codes and accessories.....	7
1.2 Connecting to the main serial port.....	8
1.3 Operation of the service serial port.....	8
1.4 Setting the network address.....	8
2.1 Power supply, sensors, digital I/O.....	9
2.2 Main serial port for connection to tLAN/pLAN/RS485 (supervisor / Modbus®).....	9
2.3 Stepper motor.....	9
2. INPUTS AND OUTPUTS	9
2.4 Relay.....	10
2.5 Service serial port.....	10
3.1 Application with μC^2 and μC^2 SE (EVD000*40* and EVD000*43*) via tLAN.....	11
3. EVD⁴ APPLICATIONS: CONNECTIONS, LIST OF PARAMETERS AND OPERATING MODES	11
3.2 Application with pCO (EVD000*40* and EVD000*43*) via tLAN.....	14
3.3 Application as positioner (EVD000*40* and EVD000*43*).....	17
3.4 Application with pCO (EVD000041* and EVD000044*) via pLAN.....	19
3.5 Application with supervisor (EVD000*42* and EVD000*45*) via RS485.....	22
3.6 Application with Modbus® protocol (EVD0001460) via RS485.....	24
4. TECHNICAL AND CONSTRUCTIONAL SPECIFICATIONS	30
5. TROUBLESHOOTING	31
APPENDIX I. INSTALLING AND USING THE EVD4-UI PROGRAM	32
I.I Installation.....	32
I.II Preparing the connections.....	32
I.III Preparing the user interface.....	32
I.IV Saving the data.....	32
I.V Loading the data.....	33
I.VI Modifying the parameters.....	33
I.VII Configurations available.....	33
APPENDIX II. DESCRIPTION OF THE PARAMETERS	34
APPENDIX III. PARAMETER SETTINGS	40
APPENDIX IV. SUMMARY OF PID CONTROL	41
IV.I Symbols used.....	41
IV.II Pid control law.....	41
IV.III Proportional action.....	41
IV.IV Integral action.....	42
IV.V Derivative action.....	43

1. INTRODUCTION

EVD⁴ is an evolved PID controller complete with driver for stepper motors specially designed for the management of electronic expansion valves in refrigerant circuits. It features sophisticated control functions and can be used in many operating configurations in refrigeration and air-conditioning systems, such as:

- PID control of superheat with protection and safety compensation functions;
- PID control on one measurement (pressure or temperature);
- positioner for electronic expansion valves controlled by 4 to 20 mA or 0 to 10 Volt signal.

The device is configured and the address set via serial interface and the user interface software is stored in non-volatile memory.

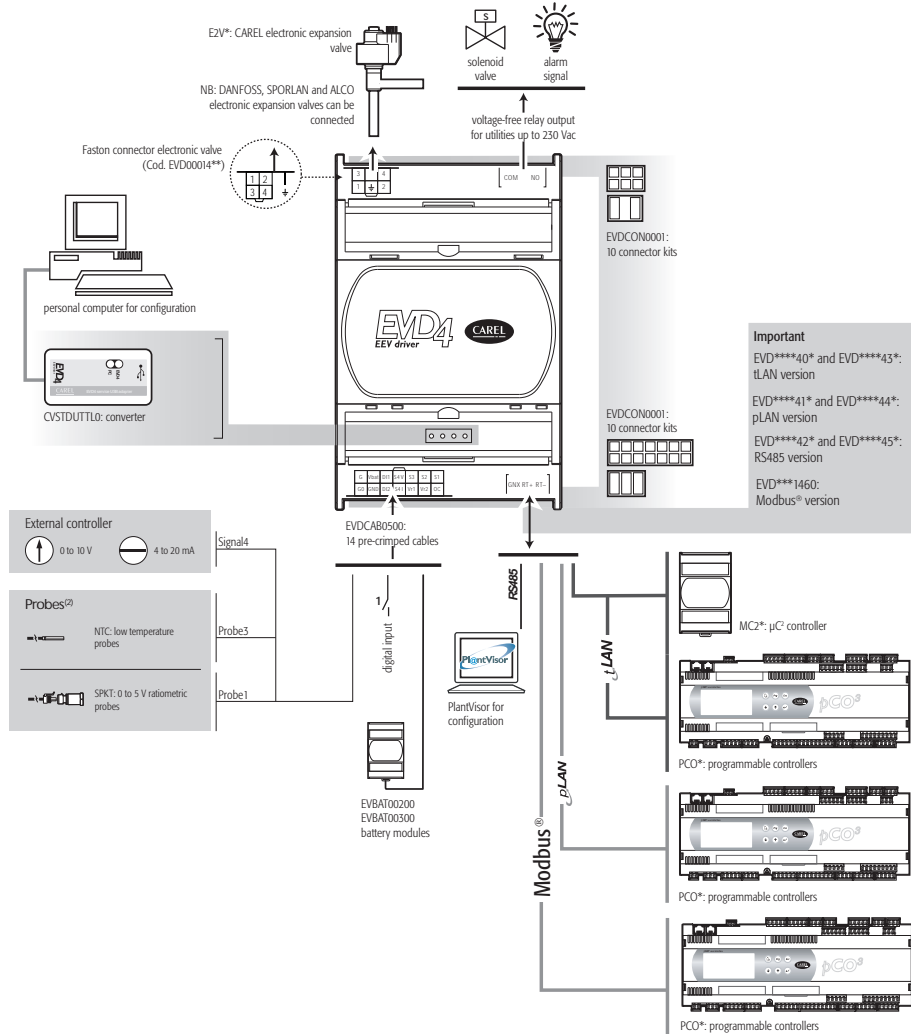

ENGLISH

Fig. 1.0

1.1 Codes and accessories

Code	Description
EVD000040*	Controller with tLAN serial already configured for operation with μC ² and μC ² SE (address 2) universal for EEV1 valves
EVD000041*	Controller with RS485 serial already configured for operation with pCO in pLAN (address 30) universal for EEV1 valves
EVD000042*	Controller with RS485 serial already configured for operation with supervisor (address 250) universal for EEV1 valves
EVD000043*	Controller with tLAN serial already configured for operation with μChiller (address 2) for CAREL valves
EVD000044*	Controller with RS485 serial already configured for operation with pCO via pLAN (address 30) for CAREL valves
EVD000045*	Controller with RS485 serial already configured for operation with supervisor (address 250) for CAREL valves
EVD00014**	EEV valve controller with spade connector ⁽³⁾
EVD0001460	Controller with RS485 serial already configured for operation with Modbus®
EVD00004*1	Multiple packages of 10 pcs, without connectors
EVBAT00200	Battery charger module and step-up transformer for backup power supply
EVBAT00300	System made up of EVBAT00200 + 12 V 1.2 Ah battery + cable and connectors
EVBATBOX10	Metal battery case
CVSTDUTTL0	USB converter to connect a PC to the service serial port
CVSTD0TTL0	RS232 converter to connect a PC to the service serial port
EVDCA80500	Package of 14 cables with terminals for MINIFIT connector, length 5 m, cross-section 1 mm ²
EVDCON0001	Packaging of connectors for 10 EVD ⁴ for multiple packages of 10 pcs

(1): See the table on the corresponding instruction sheet or APPENDIX II "DESCRIPTION OF THE PARAMETERS", "valve type" parameter

(2): For the other types of probes, see Chap. 4 "Technical and constructional characteristics"

(3): The EVD00014** series with spade and 4-pin connector on the valve side improves performance in terms of electromagnetic emissions if used with shielded cable and the shield is connected to the spade.

1.2 Connecting to the main serial port

EVD⁴ can operate independently (stand alone), connected to a supervisor to control the fundamental parameters, or connected to the LAN with other CAREL controllers, according to the following diagrams:

1.2.1 TLAN connection with μ C2 or μ C2 SE or pCO (codes EVD000*40* and EVD000*43*) Fig. 1.1.

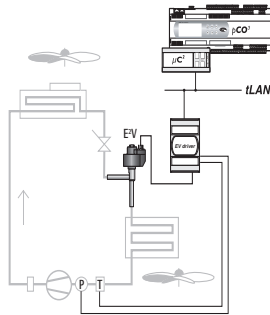

Fig. 1.1

1.2.2 pLAN connection with pCO (codes EVD000*41* and EVD000*44*) Fig. 1.2.

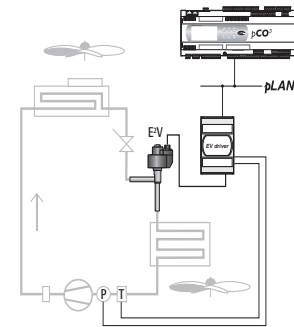

Fig. 1.2

1.2.3 Stand alone in the RS485 network with CAREL supervisor (codes EVD000*42* and EVD000*45*) or with Modbus[®] supervisor (code EVD0001460) Fig. 1.3.

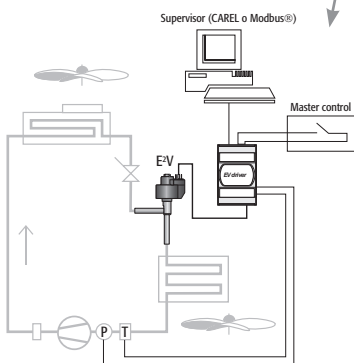

Fig. 1.3

1.3 Operation of the service serial port

The service serial port (par. 2.5) is used to access all the EVD4 parameters even when the instrument is already installed and operating; to do this, the special converter is required (CVSTDUTTLO or CVSTD0TTLO), plus a PC with USB or RS232 serial port. "APPENDIX I - Installing and using the EVD4-UI program" describes the installation and operation of the EVD4_UI software that is used to configure the controller. The converter can power the logical section of the EVD4 (but not the expansion valve), and therefore this can be configured from the PC without having to connect the instrument to the 24 Vac power supply.

1.4 Setting the network address

The EVD⁴ operating parameters, including the network address, reside on the EEPROM; to modify the values, access the service serial port using the EVD4-UI software: connect the special converter (CVSTDUTTLO or CVSTD0TTLO) to the service serial port (Fig. 2.8) and a PC with USB or RS232 serial port, then start the "EVD4_U Key" connection, as described in "APPENDIX I - Installing and using the EVD4-UI Address" and set the Net address parameter; in the box at the top right of the interface, the "Network address" item will show the new value of the address, after having pressed the "READ" button. If not changed by the user, the Net address parameter will have the following default values:

	Net address
EVD000*40* and EVD000*43*	2
EVD000*41* and EVD000*44*	30
EVD000*42* and EVD000*45*	32
EVD0001460	1

Below is a description of the connectors supplied with the EVD000*4*0 or purchased in separately in the EVDCON0001 kit for EVD000*4*1. The drawings represent the connectors as seen after having been fitted on the EVD⁴.

Note: if the address is changed using the pLAN or Modbus[®], protocol, the "Network address" item is updated after switching the device off and on again.

2. INPUTS AND OUTPUTS

Below is a description of the connectors supplied with the EVD00004*0 or purchased in separate packages (EVD400CON0 for the EVD00004*1). The drawings represent the connectors as seen after having been fitted on the EVD⁴.

2.1 Power supply, sensors, digital I/O

The main 14-pin MINIFIT[®] connector is used to connect the main and auxiliary power supply (if the EVBAT00200/300 module is fitted), as well as the sensors, digital inputs and transistor output.

This connector accepts wires with cross-section up to 1 mm² with MOLEX[®] 5556-T barrel. A kit of pre-crimped 14 x 1 mm² cables, length 5 m, is available for purchase (EVDCA0500).

line	Function
G, G0	24 Vac power supply
GND	Earth for all signals, in electrical contact with GND and the GNX terminal on the main serial connector
Vbat	Emergency power supply generated by the EVBAT00200 module
DI1, DI2	Digital inputs to be activated by voltage-free contact or transistor to GND, 5 V no-load and 5 mA short-circuited
Vr1, Vr2	5 V references used as power supply to the ratiometric probes
S1	Analogue input for ratiometric probe or NTC low temperature probe
S2	Analogue input for ratiometric probe, NTC high temperature probe or Pt1000
S3	Analogue input for ratiometric probe or NTC low temperature probe
S4I	Analogue input for 4 to 20 mA signal
S4V	Analogue input for 0 to 10 Volt signal
OC	Open-collector transistor output, for up to 100 mA

Table 2.1

For the power supply in particular, observe the diagram shown:

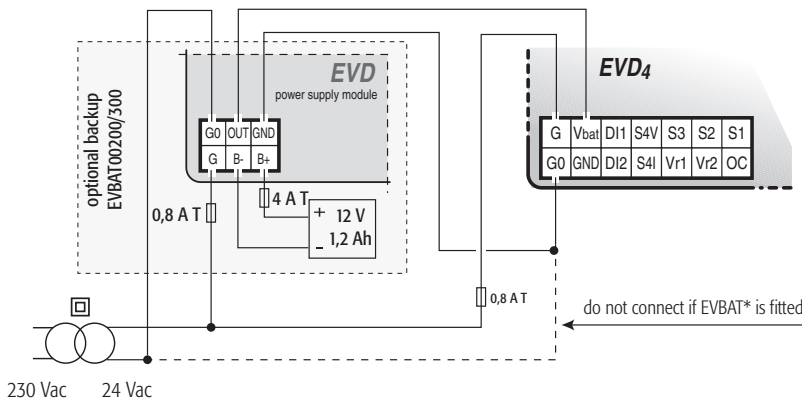

Fig. 2.2

2.2 Main serial port for connection to tLAN/pLAN/RS485 (supervisor / Modbus[®])

Removable terminal for connection to the MASTER unit (µChiller, pCO) or the supervisor (PlantVisor).

line	Function
GNX	Signal earth, in electrical contact with GND on the I/O connector
RT+	+ signal for the RS485 connection (pLAN, supervisor, Modbus [®]) or DATA signal for the tLAN connection
RT-	v signal for the RS485 connection (pLAN, supervisor, Modbus [®])

Table 2.2

2.3 Stepper motor

6-pin MINIFIT[®] connector. Accepts cables up to 1 mm² with MOLEX[®] 5556-T barrel.

Line	Function
GND	Earth electrically connected to GND on the I/O connector, and with the earth connector on the electrical panel
1	+ Phase A
2	+ Phase B
3	- Phase A
4	- Phase B

Table 2.3

MOLEX[®] Mini-Fit 538-39-01-2140

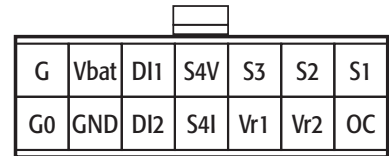
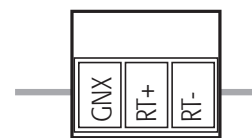

Fig. 2.1



PHOENIX[®] MC1,5/3-ST-3,81

Fig. 2.3

for code EVD00014**

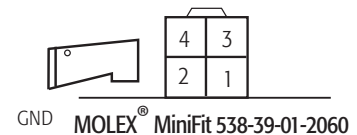

for code EVD00004**

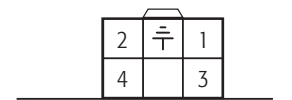

MOLEX[®] MiniFit 538-39-01-2060

Fig. 2.4

for code:
EVD00004**

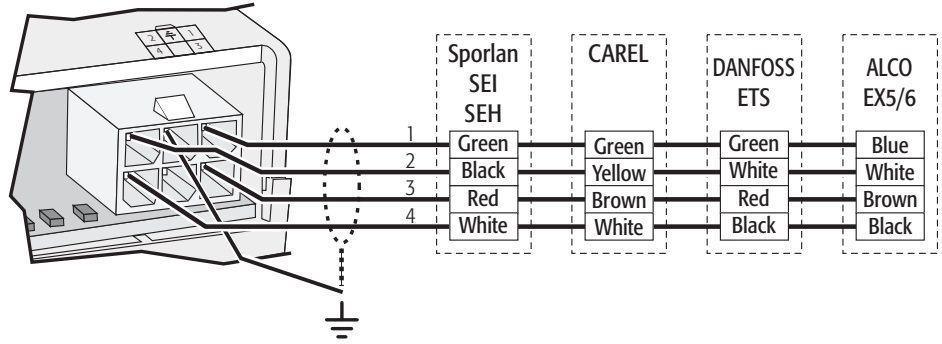

for code:
EVD00014**

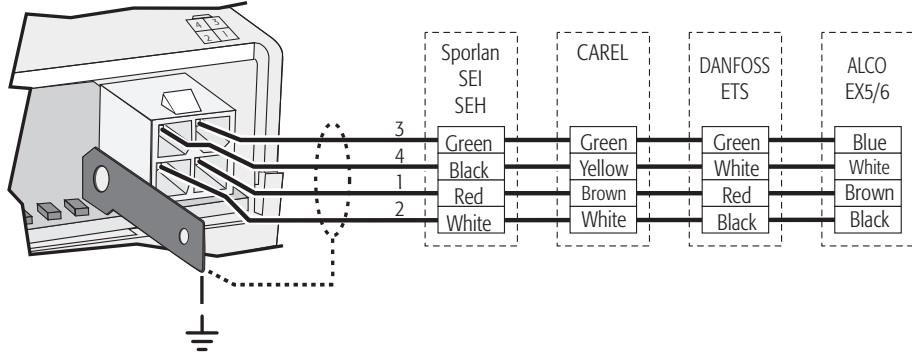
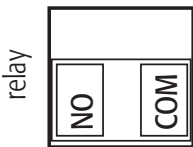

Fig. 2.5



PHOENIX® GMSTB 2,5/2 ST

Fig. 2.6

2.4 Relay

Plug-in terminal

line	Function
COM	Common
NO	Normally open contact, 5 A 250 Vac resistive load; 2 A 250 Vac, inductive load (PF= 0.4)

2.5 Service serial port

Allows access to the functions of the EVD4; via PC. To access this connector:

- 1) Remove the cover by levering it with a screwdriver on the central notch (Fig. 2.7).
- 2) Locate the white 4-pin connector and insert the special converter cable (Fig. 2.8).
Connect the USB cable to the PC; if the EVD⁴ is not powered by the 24 Vac line, it will take its power supply from the serial converter.

Once the supervisor has been connected, start an application with the supervisor protocol at 4800 baud on network address 1, for example via EVD4_UI (see APPENDIX I).

This serial port can be connected and disconnected without needing to remove the USB cable from the PC.



Fig. 2.7

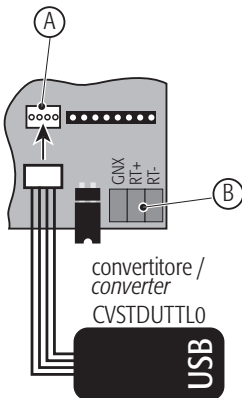

Fig. 2.8

3. EVD⁴ APPLICATIONS: CONNECTIONS, LIST OF PARAMETERS AND OPERATING MODES

Below is a description of the connections, configuration parameters, UI graphics and operating modes of the six codes available for the EVD⁴ in the different applications.

3.1 Application with μC^2 and μC^2 SE (EVD000*40* and EVD000*43*) via tLAN

3.1.1 Connections

- Communication: with reference to Fig. 3.1, connect GNX and RT+ to the μC^2 unit.
- Configuration: the EVD⁴-UI software is used to access the parameters; connect the converter (CVSTDUTTLO or CVSTD0TTL0) to the service serial port (Fig. 3.2).
- Power supply: with reference to Fig. 3.3, connect G and G0 to the 24 Vac power supply side; to connect an auxiliary battery see the EVD⁴ Instruction Sheet.
- Valve: with reference to Fig. 3.4, connect the valve according to the type set for the "Valve type" parameter.

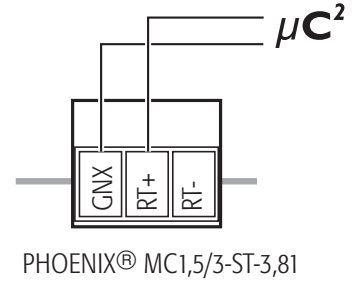
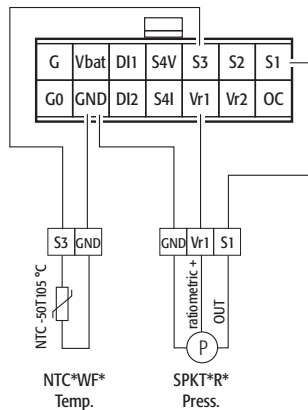
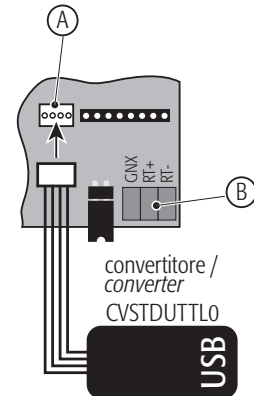

Fig. 3.1



Probes: Connect the ratiometric pressure sensors and NTC temperature sensors to S1 and S3 respectively.

For other types of probes or connections, change the value of the "EVD probes type" parameter and see chap. 4



Key:
 A Service serial port
 B Main serial port

Fig. 3.2



WARNING: if a EVD⁴ unit is erroneously connected to a controller with a different communication protocol (e.g. EVD000*40* with pCO via pLAN) and is then connected to a unit with the same protocol (e.g. EVD000*40* with pCO or μC^2 via tLAN), the first time that the EVD⁴ is connected with the correct protocol it may take a few minutes to recognise the protocol; if this waiting time seems excessive, disconnect power to the controller and the EVD⁴ (including any connections via CVSTDUTTLO or CVSTD0TTL0 converter), and then reconnect the devices (including any connection via CVSTDUTTLO or CVSTD0TTL0 converter) and wait a few minutes for the connection to be restored independently. In the event of connection to μC^2 , after having reconnected the devices to the power supply, connect the EVD⁴ to a PC and activate the EVD⁴_UI using the "EVD⁴_UI MCH2" connection, set En. reset to default = 14797, then Reset to default = Yes (the box changes from green to red).

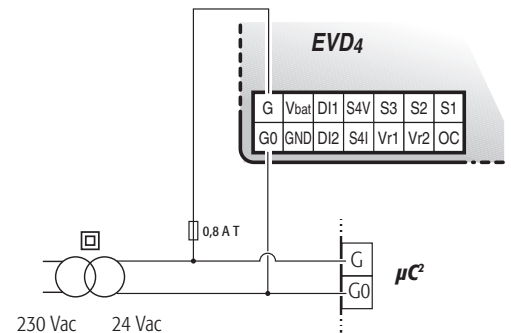
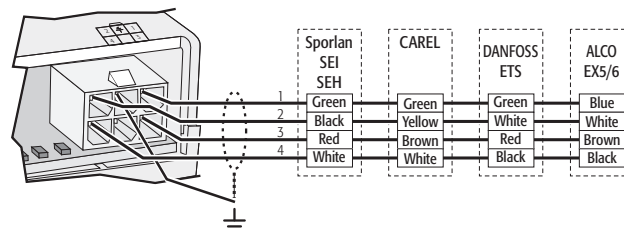

Fig. 3.3

for code:
EVD00004**



for code:
EVD00014**

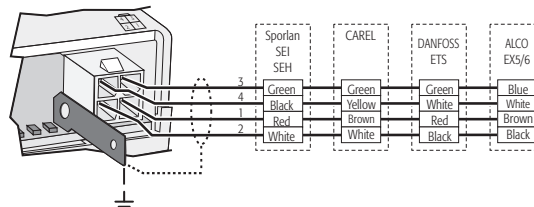

Fig. 3.4

3.1.2 List of parameters

Below is the list of parameters visible on the EVD4-UI, divided into write and read; the meaning of each parameter is described in APPENDIX II, while APPENDIX III shows a list of the values of the reference parameters in relation to certain typical applications.

Key:

- = Main parameters required to start operation;
- = Secondary parameters required for optimum operation;
- = Advanced parameters.

WRITE

Mode	Parameter name	Description of the parameter	
Mode dependent parameters (Fig. 3.5)			
COOL	CH-Superheat set	superheat set point in CH mode	■
	CH-Proportional gain	PID proportional factor in CH mode	■
	CH-Integral time	integral time for superheat control in CH mode	■
	CH-Low Superheat	low superheat value in CH mode	□
	LOP Cool Mode	temperature at minimum operating pressure (MOP) in CH mode	□
HEAT	MOP Cool Mode	temperature at maximum operating pressure (MOP) in CH mode	□
	HP-Superheat set	superheat set point in HP mode	■
	HP-Proportional gain	PID proportional factor in HP mode	■
	HP-Integral time	integral time for superheat control in HP mode	■
	HP-Low Superheat	low superheat value in HP mode	□
DEFROST	LOP Heat Mode	temperature at minimum operating pressure (LOP) in HP mode	□
	MOP Heat Mode	temperature at maximum operating pressure (MOP) in HP mode	□
	DF-Superheat set	superheat set point in DF mode	■
	DF-Proportional gain	PID proportional factor in DF mode	■
	DF-Integral time	integral time for superheat control in DF mode	■
COMMON	DF-Low Superheat	low superheat value in DF mode	□
	LOP Defr. Mode	temperature at minimum operating pressure (LOP) in DF mode	□
	MOP Defr. Mode	temperature at maximum operating pressure (MOP) in DF mode	□
	Circuit/EEV ratio	percentage of the maximum capacity managed by the valve in the circuit where it is installed	■
	Dynamic proportional gain	attenuation coefficient with change in capacity	–
	SHeat dead zone	dead zone for PID control	–
	Derivative time	PID derivative time	–
	Low SHeat int. time	integral time for low superheat control	–
	LOP integral time	integral time for low evaporation pressure (LOP) control	–
	MOP integral time	integral time for high evaporation pressure (MOP) control	–
	Hi TCond. int. time	integral time for high condensing pressure control (HiTcond)	–
	Hi TCond. protection	maximum condensing temperature	–
	Alarms delay Low SH	low superheat alarm delay	–
	Alarms delay LOP	low evaporation pressure (LOP) alarm delay	–
	Alarms delay MOP	high evaporation pressure (MOP) alarm delay	–
MOP startup delay	MOP delay time	–	
Alarms delay probe error	probe error alarm delay	–	
Global parameters (Fig. 3.5)			
	MODE	READ ONLY, received from μC^2	–
	REGULATION	READ ONLY, received from μC^2	–
	Refrigerant	number indicating the type of refrigerant used	
	EVD probes type	number indicating the combination of sensors used to calculate the superheat	–
	Valve type	number that defines the type of electronic valve used	
	EEV mode man.	enable/disable manual valve positioning	–
	Requested steps	required motor position in manual control	–
	Open relay low SH	enable/disable relay opening following low superheat	–
	Open relay MOP	enable/disable relay opening following MOP	–
	Valve alarm	enable/disable valve alarm (valve not closed at shutdown alarm)	o
	S1 probe limits Min value	'zero' scale for pressure sensor on input S1	
	S1 probe limits Max value	end scale for pressure sensor on input S1	
	S2-Pt1000 calib.	calibration index for PT1000 sensor	–
	Probes offset S1	correction of the lower limit of S1	–
	Probes offset S2	correction of the lower limit of S2	–
	Probes offset S3	correction of the lower limit of S3	–
	Enable reset to default	enable restore default parameters	–
	Reset to default	confirm enable default parameters	–
	Standby steps	number of valve standby steps	–
	Blocked valve check	time after which, in certain conditions, the valve is considered as being blocked	–
	Go ahead	enable restart following error	–

READ

Parameter name	Description
System measurements (Fig. 3.5)	
EEV opening	valve opening as a %
EEV position	position of the valve in steps
Act. SH set	current superheat set point
Superheat	superheat value measured
Ev. probe press.	evaporation pressure value measured
Ev. probe sat. temp.	saturated gas temperature value calculated in the evaporator
Suction temp.	compressor suction temperature value measured
Cond. probe press.	condensing pressure value measured, from μC^2
Cond. probe sat. temp.	saturated gas temperature in the condenser
Digital variables (Fig. 9)	
μC^2 off line	active when μC^2 is not connected to EVD ⁴
50% capacity	active when the capacity of the circuit is 50%
100% capacity	active when the capacity of the circuit is 100%
alarm Low Superheat	active in low superheat conditions
alarm MOP timeout	active in conditions with excessive evaporation pressure
alarm LOP timeout	active in conditions with excessive evaporation pressure
EEV not closed	active due to failed valve closing
Low SH status	active when in low superheat control status
MOP status	active when in maximum evaporation pressure control status
LOP status	active when in minimum evaporation pressure control status
High Tc status	active when in high condensing temperature control status
alarm Eeprom error	active following an EEPROM memory error
alarm probe error	active following an error on the signal from the probe

3.1.3 EVD4_UI user interface

The EVD4_UI user interface is based on the CAREL supervisor protocol and is designed for the easy and intuitive reading or configuration of the control parameters. The program can be started in different configurations so as to display the set of parameters that is suitable for the type of installation the EVD⁴ is used in; to do this, make the connection using the name of the required configuration. The interface configuration for μC^2 is shown in Fig. 3.5 and is activated by making the "EVD4_UI MCH2" connection, as described in APPENDIX I "INSTALLING AND USING THE EVD4_UI PROGRAM".

3.1.4 Start-up

After having connected the EVD⁴, as described in 3.1.1, connect the service serial port to a PC using the special converter and configure the values of the parameters and the address using the software described in 3.1.3 according to the application and/or systems used. The parameters can be accessed for read and write even if the EVD4 is not powered, as the converter or the programming key provide the power supply to the driver, excluding the valve.

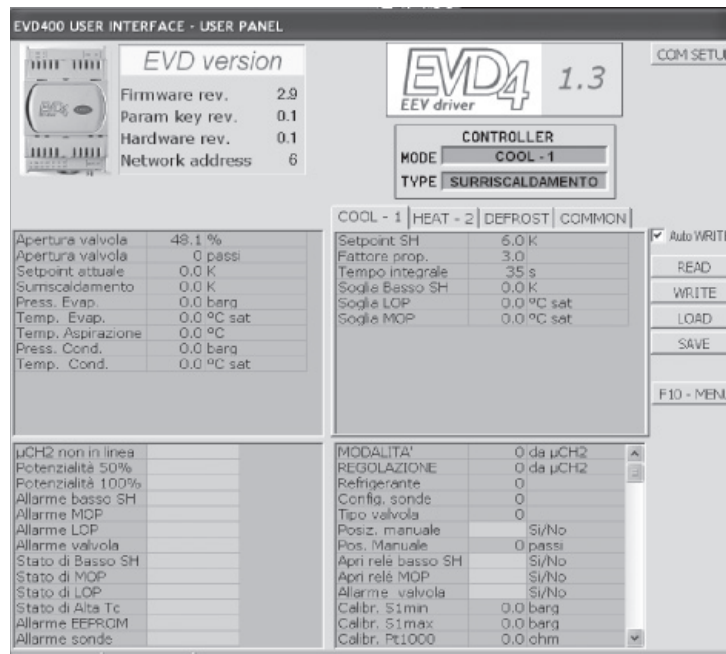
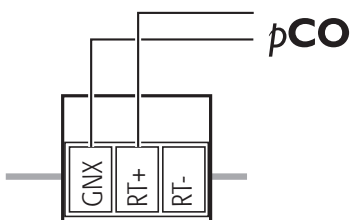

Fig. 3.5

3.2 Application with pCO (EVD000*40* and EVD000*43*) via tLAN



PHOENIX® MC1,5/3-ST-3,81

Fig. 3.6

3.2.1 Connections

Communication: with reference to Fig. 3.6, connect GNX and RT+ to the pCO unit.

Power supply: with reference to Fig. 3.7, connect G and G0 to the 24 Vac power supply side;

Valve: with reference to Fig. 3.8, connect the valve according to the type set for the "Valve type" parameter.

Probes: Connect the ratiometric pressure sensors and NTC temperature sensors to S1 and S3 respectively.

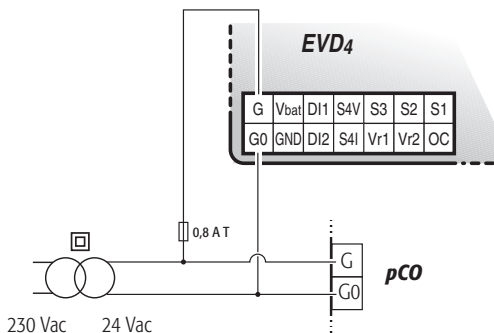
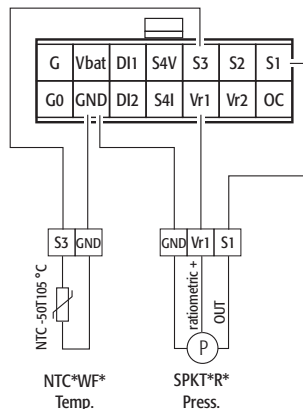
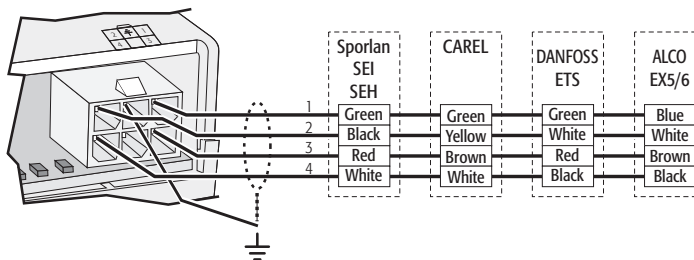

Fig. 3.7



For other types of probes or connections, change the value of the "EVD probes type" parameter and see chap. 4

for code:
EVD00004**



for code:
EVD00014**

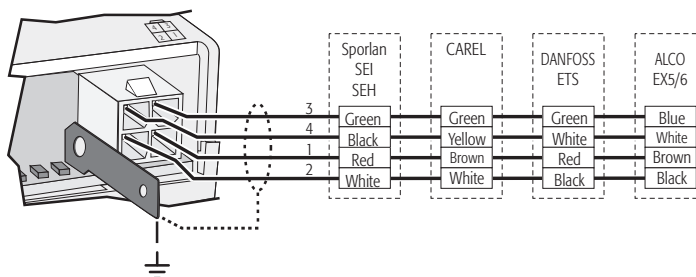

Fig. 3.8

3.2.2 List of parameters

Below is the list of parameters; the meaning of each is detailed in APPENDIX II, while APPENDIX III shows a list of the values of the reference parameters in relation to the most common applications.

In the standard application, the EVD4 read and write parameters are organised into three groups, accessible from a pCO terminal: input/output, maintenance and manufacturer

The SYSTEM SET level must be compiled, as this contains the information on what is physically installed in the system. Selecting the type of driver and enabling any advanced functions will allow access to specific fields/masks in this or other menus.

The AUTO SETUP level of parameters must also be compiled, and contains fundamental information on the type of unit.

The ADVANCED SET branch is not required for standard superheat control and is provided for expert users and/or to implement non-standard functions.

Key:

- = Main parameters required to start operation;
- = Secondary parameters required for optimum operation;
- = Advanced parameters.

**MANUFACTURER group
SYSTEM SET**

	Parameter name	Description	
	EVD type	model of EVD used, from pCO	■
	EVD probes type	number indicating the combination of sensors used to calculate the superheat	■
	Valve type	number that defines the type of electronic valve used	■
	Battery presence	enable valve not closed error, to be entered if the battery is present	■
	Refrigerant	number indicating the type of refrigerant used	■
Custom valve configuration	Minimum steps	minimum control steps	–
	Maximum steps	maximum control steps	–
	Closing steps	steps completed in total closing	–
	Opening extra steps	enable extra steps in opening	–
	Closing extra steps	enable extra steps in closing	–
	Phase current	peak current per phase	–
	Still current	current with the motor off	–
	Steprate	motor speed	–
	Duty cycle	motor duty cycle	–
		EEV stand-by steps	number of valve standby steps, see standby steps
	S1 probe limits Min	'zero' scale for pressure sensor on input S1	■
	S1 probe limits Max	end scale for pressure sensor on input S1	■
	S2-Pt1000 calib.	calibration index for PT1000 sensor	–
Alarms delay	Alarms delay Low SH	low superheat alarm delay	–
	Alarms delay High SH	high superheat temperature alarm delay in CH mode	–
	Alarms delay LOP	low evaporation pressure (LOP) alarm delay	–
	Alarms delay MOP	high evaporation pressure (MOP) alarm delay	–
	Alarms delay probe error	probe error alarm delay	–
	Stand alone	enable StandAlone	–

AUTOSETUP

	Parameter name	Description	
	Re-install AUTOSETUP values	confirm enable restore parameter default values	■
	Circuit/EEV ratio	percentage of the maximum capacity managed by the valve in the circuit where it is installed	■
	Compressor or unit	macroblock parameter that defines the integral time	■
	Capacity control	macroblock parameter that defines the proportional factor	■
Evaporator Type	Cool	macroblock parameter that defines the integral time	■
	Heat	macroblock parameter that defines the integral time	■
MOP	Cool Mode	temperature at minimum operating pressure (MOP) in CH mode	□
	Heat Mode	temperature at minimum operating pressure (LOP) in HP mode	□
	Defr. Mode	temperature at minimum operating pressure (LOP) in DF mode	□
	Cool Mode	temperature at maximum operating pressure (MOP) in CH mode	□
	Standby steps	temperature at maximum operating pressure (MOP) in HP mode	□
	Defr. Mode	temperature at maximum operating pressure (MOP) in DF mode	□
	High SH alarm threshold	maximum superheat temperature	–

ADVANCED SETTINGS – FINE TUNING

	Parameter name	Description	
cool mode adjust	CH-Circuit/EEV Ratio	percentage of the maximum capacity managed by the valve in the circuit where it is installed, in CH mode	–
	CH-Superheat set	superheat set point in CH mode	–
	CH-Proportional gain	PID proportional factor in CH mode	–
	CH-Integral time	integral time for superheat control in CH mode	–
heat mode adjust	CH-Low Superheat	low superheat value in CH mode	–
	HP-Circuit/EEV Ratio	percentage of the maximum capacity managed by the valve in the circuit where it is installed, in HP mode	–
	HP-Superheat set	superheat set point in HP mode	–
	HP-Proportional gain	PID proportional factor in HP mode	–
	HP-Integral time	integral time for superheat control in HP mode	–
defr. mode adjust	HP-Low Superheat	low superheat value in HP mode	–
	DF-Circuit/EEV Ratio	percentage of the maximum capacity managed by the valve in the circuit where it is installed, in DF mode	–
	DF-Superheat set	superheat set point in DF mode	–
	DF-Proportional gain	PID proportional factor in DF mode	–
common list adjust	DF-Integral time	integral time for superheat control in DF mode	–
	DF-Low Superheat	low superheat value in DF mode	–
	SHeat dead zone	dead zone for PID control	–
	Derivative time	PID derivative time	–
	Low SHeat int. time	integral time for low superheat control	–
	LOP integral time	integral time for low evaporation pressure (LOP) control	–
	MOP integral time	integral time for high evaporation pressure (MOP) control	–
	MOP startup delay	MOP delay time	–
	Hi TCond. protection	maximum condensing temperature	–
	Hi TCond. int. time	integral time for high condensing pressure control (HiTcond)	–
	Dynamic prop. gain	attenuation coefficient with change in capacity	–
	Blocked valve check	time after which, in certain conditions, the valve is considered as being blocked	–

INPUT/OUTPUT group

	Parameter name	Description
	DriverX mode	operating mode of the X-th driver, from pCO
	EEV mode man.	enable/disable manual valve positioning
	EEV position	calculated electronic expansion valve opening position
	Power request	cooling capacity, from pCO
	RXXX	refrigerant configured for the REFRIGERANT parameter
	Superheat	superheat value measured
	Saturated temp.	see Ev. probe sat. temp.
	Suction temp.	compressor suction temperature value measured
Evaporation probe	Pressure	evaporation pressure value measured
	Saturated Temp.	saturated gas temperature value calculated in the evaporator
Condensation probe	Pressure	condensing pressure value measured, from pCO
	Saturated temp	saturated gas temperature value calculated in the condenser, calculated from dry on previous condensing pressure
	Aux. probe	value measured by the auxiliary probe set for the AUX. PROBE CONFIG. parameter
	Act. SH set	current superheat set point
	EVD version H.W	driver hardware version
	EVD version S.W	software version installed on the driver

MAINTENANCE group

	Parameter name	Description
Manual mng. driver 'X'	EEV Mode	electronic expansion valve control mode, read EEV mode man.
	Requested steps	required motor position in manual control.
	EEV position	calculated electronic expansion valve opening position
Driver 'X' status	Go ahead	enable restart following error
	Probes offset S1	correction of the lower limit of S1
	Probes offset S2	correction of the lower limit of S2
	Probes offset S3	correction of the lower limit of S3

ADVANCED SETTINGS – SPECIAL TOOLS

Not available

ALARMS (for driver 'X')

Parameter name	Description
alarm probe error	active following an error on the signal from the probe
alarm Eeprom error	active following an EEPROM memory error
alarm MOP timeout	active in conditions with excessive evaporation pressure
alarm LOP timeout	active in conditions with insufficient evaporation pressure
alarm Low Superheat	active in low superheat conditions
EEV not closed	active due to failed valve closing
driver X high superheat	driver X with high superheat

3.2.3 Start-up

After having connected the EVD⁴, as described in 3.4.1, configure the parameters listed in 3.4.2 using the display that manages the pCO, according to the application and/or systems used. For the unit to be correctly operated, the SYSTEM SET and AUTOSETUP levels need to be compiled.

The SYSTEM SET level must be compiled, as this contains the information on what is physically installed in the system. Selecting the type of driver and enabling any advanced functions will allow access to specific fields/masks in this or other menus.

The AUTO SETUP level of parameters must also be compiled, and contains fundamental information on the type of unit.

The ADVANCED SET branch is not required for standard superheat control and is provided for expert users and/or to implement non-standard functions.

If some essential fields have not been configured, the alarm message – DRIVER "x" AUTOSETUP PROCEDURE NOT COMPLETED – will prevent the unit from being started until the autosetup procedure has been completed.

3.3 Application as positioner (EVD000*40* and EVD000*43*)

The EVD⁴ code EVD000*40* (or EVD000*43*) can be used as a positioner for electronic expansion valves, proportional to a 4 to 20 mA or 0 to 10 Volt signal from a controller.

3.3.1 Connections

- Communication: connect S4I and GND to the controller for 4 to 20 mA signals;
connect S4V and GND to the controller for 0 to 10 Volt signals (Fig. 3.9).
- Configuration: connect the converter (CVSTDUTTLO or CVSTD0TTLO) to the service serial port and to a PC with USB or RS232 (Fig. 3.10).
- Power supply: with reference to Fig. 3.11, connect G and G0 to the 24 Vac power supply side.
- Valve: with reference to Fig. 3.12 connect the valve according to the type set for the "Valve type" parameter.

for code:
EVD00004**

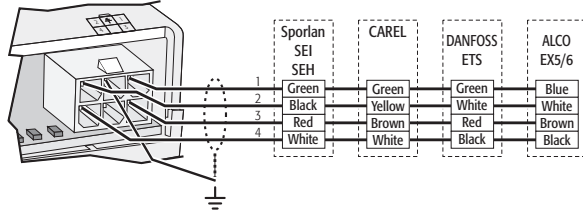

for code:
EVD00014**

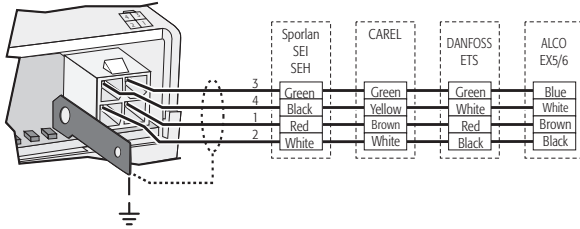

Fig. 3.12

3.3.2 List of parameters

Below is the list of parameters visible on the EVD4-UI, divided into read and write; the meaning of each parameter is detailed in APPENDIX II.

- Key:
- = Main parameters required to start operation;
 - = Secondary parameters required for optimum operation;
 - = Advanced parameters.

WRITE

Parameter name	Description
Mode dependent parameters (Fig. 9)	
Calibr. S4 gain mA	current gain on channel S4
Calibr. S4 offs mA	current offset on channel S4
Calibr. S4 gain Volt	voltage gain on channel S4
Calibr. S4 offs Volt	voltage offset on channel S4
Global parameters (Fig. 9)	
Regulation type	type of control ■
EEV mode man.	enable/disable manual valve positioning
Requested steps	required motor position in manual control
S4 probe type	type of probe on channel S4 ■
Valve type	number that defines the type of electronic valve used ■
KEY 1	
KEY 12	
En. positioner	enable positioner function ■

READ

System measurements (Fig. 9)	
Parameter name	Description
EEV opening	valve opening as a %
EEV position	position of the valve in steps
S4 signal	signal on input S4
Digital variables (Fig. 9)	
Reset to default	confirm enable default parameters
Functional test	functional test
Digital input 1	status of digital input 1
Stand alone	select stand-alone operation

MOLEX®
Mini-Fit 538-39-01-2140

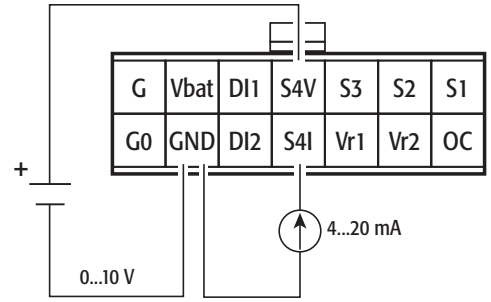
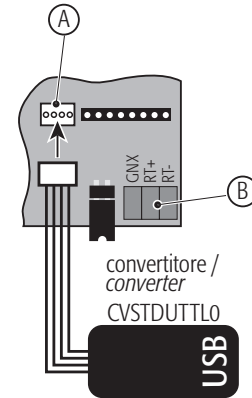

Fig. 3.9



- Key:
- A | Service serial port
 - B | Main serial port

Fig. 3.10

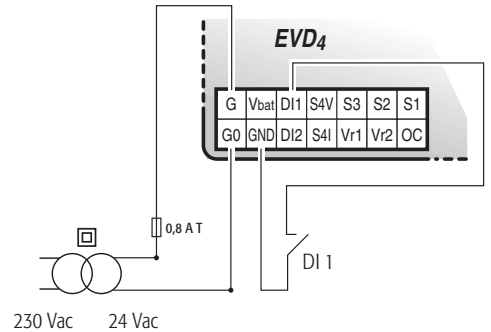

Fig. 3.11

3.3.3 EVD4_UI user interface

The EVD4_UI user interface is based on the CAREL supervisor protocol and is designed for the easy and intuitive reading or configuration of the control parameters. The program can be started in different configurations so as to display the set of parameters that is suitable for the type of installation the EVD⁴; is used in; to do this, make the connection using the name of the required configuration. The interface configuration for the 'positioner' function is shown in Fig. 3.13 and is activated by making the "EVD4_UI positioner" connection.

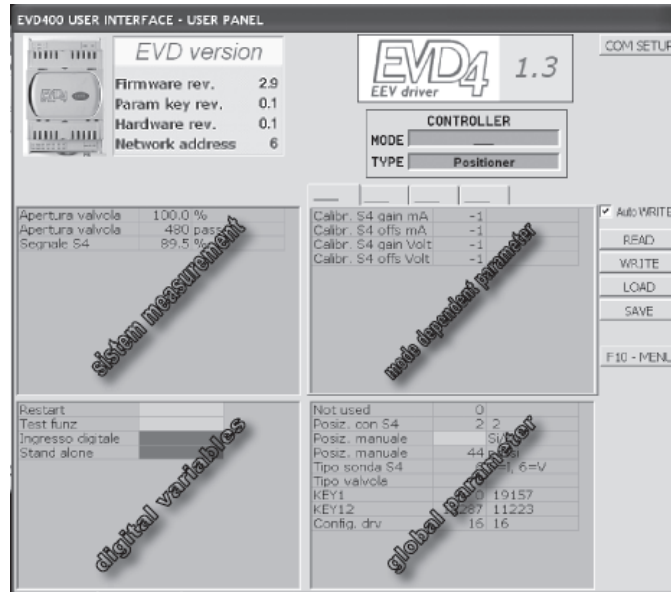

Fig. 3.13

3.3.4 Start-up

After having connected the EVD⁴ as described in 3.3.1, connect the service serial port to a PC using the converter and configure the values of the parameters listed in 3.3.2 using the software described in 3.3.3 as follows:

- Power up the EVD⁴ from the mains or via converter
- Connect EVD4 to the PC via the converter
- Set "S4 probe type" = 5 (configuration of input S4 as 4 to 20 mA) or 6 (0 to 10 V)
- Close input DI1
- Set "posit. with S4" = 2
- Activate "stand alone"

To calibrate the analogue inputs, proceed as follows:

- Reset the EVD4 by activating the digital variable "Reset to default"
- Within 30 seconds write 19157 to KEY1 (functional test mode)
- Write 1223 to KEY12 (disable exit the functional test by timeout, within 250 seconds)
- Activate the Functional test digital variable; the calibration parameters are now accessible in write mode
- Set the Calibr. S4 gain mA and Calibr. S4 offs mA parameters to zero for 4 to 20 mA operation, or alternatively Calibr. S4 gain Volt and Calibr. S4 offs Volt for 0 to 10 Volt operation
- Set S4 probe type = 5 (configuration of input S4)

The parameters can be accessed for read and write even if the EVD⁴ is not powered, as the converter or the programming key provide the power supply to the driver, excluding the valve

3.4 Application with pCO (EVD000041* and EVD000044*) via pLAN

3.4.1 Connections

Communication: connect GNX, RT+ and RT- to the pCO unit (Fig. 3.14).

Power supply: connect G and GO to the 24 Vac (Fig. 3.15).

Valve: with reference to Fig. 3.16, connect the valve according to the type set for the "Valve type" parameter;

Probes: Connect the ratiometric pressure sensors and NTC temperature sensors to S1 and S3 respectively.

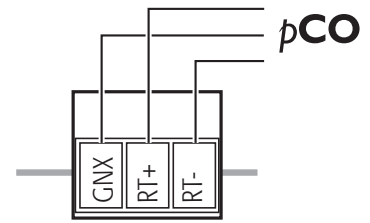

PHOENIX® MC1,5/3-ST-3,81

Fig. 3.14

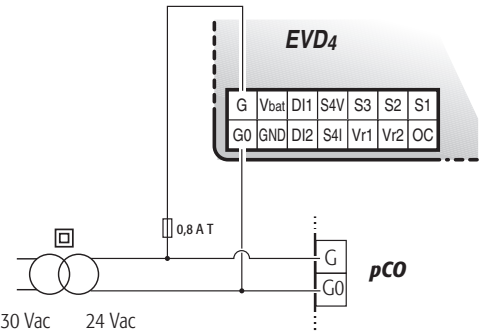
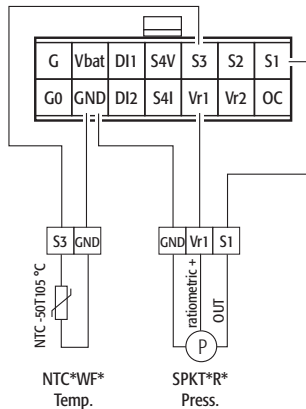
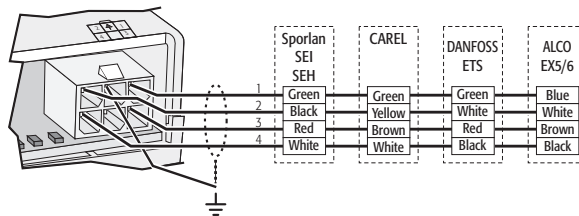

Fig. 3.15

For other types of probes or connections, change the value of the "EVD probes type" parameter and see chap. 4

for code:
EVD00004**



for code:
EVD00014**

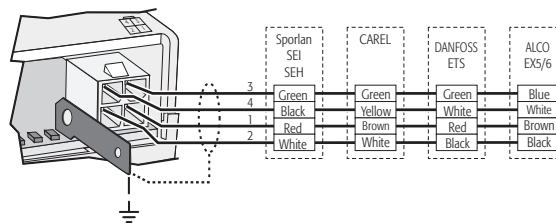

Fig. 3.16

3.4.2 List of parameters

Below is the list of parameters; the meaning of each is detailed in APPENDIX II, while APPENDIX III shows a list of the values of the reference parameters in relation to the most common applications.

In the standard application, the EVD4 read and write parameters are organised into three groups, accessible from a pCO terminal: input/output, maintenance and manufacturer

The SYSTEM SET level must be compiled, as this contains the information on what is physically installed in the system. Selecting the type of driver and enabling any advanced functions will allow access to specific fields/masks in this or other menus.

The AUTO SETUP level of parameters must also be compiled, and contains fundamental information on the type of unit.

The ADVANCED SET branch is not required for standard superheat control and is provided for expert users and/or to implement non-standard functions.

MANUFACTURER group

SYSTEM SET

Key:

- = Main parameters required to start operation;
- = Secondary parameters required for optimum operation;
- = Advanced parameters.

Parameter name	Description	
EVD type	model of EVD used, from pCO	■
EVD probes type	number indicating the combination of sensors used to calculate the superheat	■
Valve type	number that defines the type of electronic valve used	■
Battery presence	enable valve not closed error, to be entered if the battery is present	■
Refrigerant	number indicating the type of refrigerant used	■

Custom valve configuration	Minimum steps	minimum control steps	-
	Maximum steps	maximum control steps	-
	Closing steps	steps completed in total closing	-
	Opening extra steps	enable extra steps in opening	-
	Closing extra steps	enable extra steps in closing	-
	Phase current	peak current per phase	-
	Still current	current with the motor off	-
	Steprate	motor speed	-
	Duty cycle	motor duty cycle	-
Alarms delay	EEV stand-by steps	number of valve standby steps, see standby steps	-
	S1 probe limits Min	'zero' scale for pressure sensor on input S1	■
	S1 probe limits Max	end scale for pressure sensor on input S1	■
	S2-Pt1000 calib.	calibration index for PT1000 sensor	-
	Alarms delay Low SH	low superheat alarm delay	-
	Alarms delay High SH	high superheat temperature alarm delay in CH mode	-
	Alarms delay LOP	low evaporation pressure (LOP) alarm delay	-
Alarms delay	Alarms delay MOP	high evaporation pressure (MOP) alarm delay	-
	Alarms delay probe error	probe error alarm delay	-
	Stand alone	enable StandAlone	-

AUTOSETUP

	Parameter name	Description	
Evaporator Type	Re-install AUTOSETUP values	confirm enable restore parameter default values	■
	Circuit/EEV ratio	percentage of the maximum capacity managed by the valve in the circuit where it is installed	■
	Compressor or unit	macroblock parameter that defines the integral time	■
	Capacity control	macroblock parameter that defines the proportional factor	■
	Cool	macroblock parameter that defines the integral time	■
	Heat	macroblock parameter that defines the integral time	■
	Cool Mode	temperature at minimum operating pressure (MOP) in CH mode	□
	Heat Mode	temperature at minimum operating pressure (LOP) in HP mode	□
	Defr. Mode	temperature at minimum operating pressure (LOP) in DF mode	□
	MOP	Cool Mode	temperature at maximum operating pressure (MOP) in CH mode
Standby steps		temperature at maximum operating pressure (MOP) in HP mode	□
Defr. Mode		temperature at maximum operating pressure (MOP) in DF mode	□
	High SH alarm threshold	maximum superheat temperature	-

ADVANCED SETTINGS – FINE TUNING

	Parameter name	Description	
cool mode adjust	CH-Circuit/EEV Ratio	percentage of the maximum capacity managed by the valve in the circuit where it is installed, in CH mode	-
	CH-Superheat set	superheat set point in CH mode	-
	CH-Proportional gain	PID proportional factor in CH mode	-
	CH-Integral time	integral time for superheat control in CH mode	-
	CH-Low Superheat	low superheat value in CH mode	-
heat mode adjust	HP-Circuit/EEV Ratio	percentage of the maximum capacity managed by the valve in the circuit where it is installed, in HP mode	-
	HP-Superheat set	superheat set point in HP mode	-
	HP-Proportional gain	PID proportional factor in HP mode	-
	HP-Integral time	integral time for superheat control in HP mode	-
	HP-Low Superheat	low superheat value in HP mode	-
defr. mode adjust	DF-Circuit/EEV Ratio	percentage of the maximum capacity managed by the valve in the circuit where it is installed, in DF mode	-
	DF-Superheat set	superheat set point in DF mode	-
	DF-Proportional gain	PID proportional factor in DF mode	-
	DF-Integral time	integral time for superheat control in DF mode	-
	DF-Low Superheat	low superheat value in DF mode	-
common list adjust	SHeat dead zone	dead zone for PID control	
	Derivative time	PID derivative time	
	Low SHeat int. time	integral time for low superheat control	
	LOP integral time	integral time for low evaporation pressure (LOP) control	
	MOP integral time	integral time for high evaporation pressure (MOP) control	
	MOP startup delay	MOP delay time	
		Hi TCond. protection	maximum condensing temperature
	Hi TCond. int. time	integral time for high condensing pressure control (HiTcond)	
	Dynamic prop. gain	attenuation coefficient with change in capacity	
	Blocked valve check	time after which, in certain conditions, the valve is considered as being blocked	

INPUT/OUTPUT group

	Parameter name	Description
	DriverX mode	operating mode of the X-th driver, from pCO
	EEV mode man.	enable/disable manual valve positioning
	EEV position	calculated electronic expansion valve opening position
	Power request	cooling capacity, from pCO
	RXXX	refrigerant configured for the REFRIGERANT parameter
	Superheat	superheat value measured
	Saturated temp.	see Ev. probe sat. temp.
Evaporation probe	Suction temp.	compressor suction temperature value measured
	Pressure	evaporation pressure value measured
Condensation probe	Saturated Temp.	saturated gas temperature value calculated in the evaporator
	Pressure	condensing pressure value measured, from pCO
	Saturated temp	saturated gas temperature value calculated in the condenser, calculated from dry on previous condensing pressure
	Aux. probe	value measured by the auxiliary probe set for the AUX. PROBE CONFIG. parameter
	Act. SH set	current superheat set point
	EVD version H.W	driver hardware version
	EVD version S.W	software version installed on the driver

MAINTENANCE group

	Parameter name	Description
Manual mng. driver 'X'	EEV Mode	electronic expansion valve control mode, read EEV mode man.
	Requested steps	required motor position in manual control.
	EEV position	calculated electronic expansion valve opening position
Driver 'X' status	Go ahead	enable restart following error
	Probes offset S1	correction of the lower limit of S1
	Probes offset S2	correction of the lower limit of S2
	Probes offset S3	correction of the lower limit of S3

ADVANCED SETTINGS – SPECIAL TOOLS

Not available

ALARMS (for driver 'X')

Parameter name	Description
alarm probe error	active following an error on the signal from the probe
alarm Eeprom error	active following an EEPROM memory error
alarm MOP timeout	active in conditions with excessive evaporation pressure
alarm LOP timeout	active in conditions with insufficient evaporation pressure
alarm Low Superheat	active in low superheat conditions
EEV not closed	active due to failed valve closing
driver X high superheat	driver X with high superheat

3.4.3 Start-up

After having connected the EVD⁴, as described in 3.4.1, configure the parameters listed in 3.4.2 using the display that manages the pCO, according to the application and/or systems used. For the unit to be correctly operated, the SYSTEM SET and AUTOSETUP levels need to be compiled.

If some essential fields have not been configured, the alarm message

– DRIVER "x" AUTOSETUP PROCEDURE NOT COMPLETED –

will prevent the unit from being started until the autoseup procedure has been completed.

3.5 Application with supervisor (EVD000*42* and EVD000*45*) via RS485

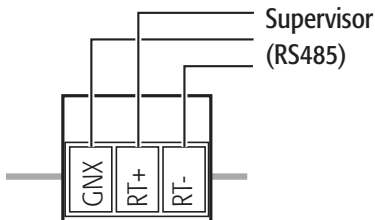

PHOENIX® MC1,5/3-ST-3,81

Fig. 3.17

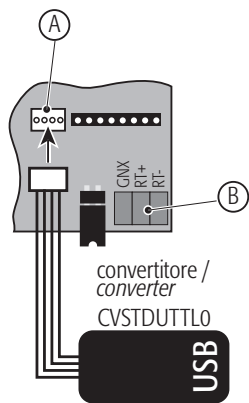

Fig. 3.18

Key:
 A Service serial port
 B Main serial port

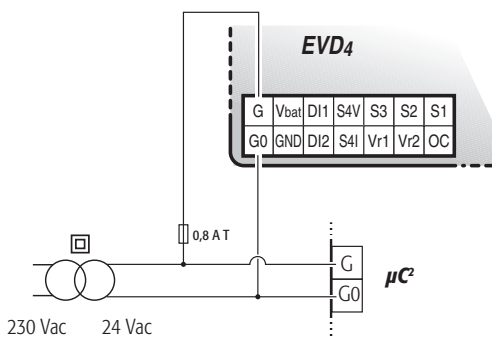

Fig. 3.19

3.5.1 Connections

Communication: connect GNX, RT+ and RT- to the converter CVSTDUMOR0 (Fig 3.17).
 Configuration: Connect the converter (CVSTDUTTLO or CVSTD0TTL0) to the service serial port and to a PC with USB or RS232 serial port (Fig. 3.18).
 Power supply: connect G and G0 to the 24 Vac power supply (Fig 3.19)
 Valve: connect the valve according to the type set for the "Valve type" parameter (Fig. 3.20).
 Probes: Connect the ratiometric pressure sensors and NTC temperature sensors to S1 and S3 respectively.

For other types of probes or connections, change the value of the "EVD

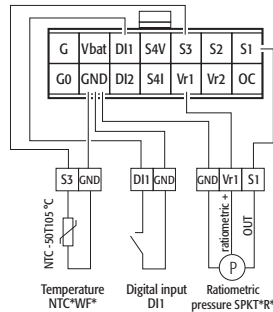

Fig. 3.20

probes type" parameter and see technical leaflet.

3.5.2 List of parameters

Below is the list of parameters visible from the EVD4-UI, divided into write and read; the meaning of each is

for code:
 EVD00004**

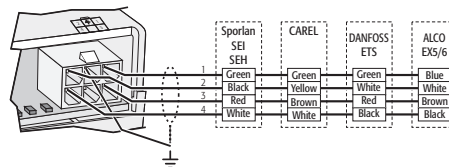

for code:
 EVD00014**

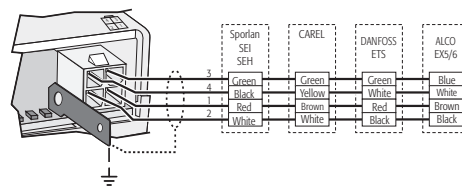

detailed in APPENDIX II, while APPENDIX III shows a list of the values of the reference parameters in relation to certain applications. Key: ■ = Main parameters required to start operation; □ = Secondary parameters required for optimum operation; - = Advanced parameters.

WRITE

Mode	Parameter name	Parameter description	
		Mode dependent parameters (Fig. 3.21)	
Main	Circuit/EEV ratio	percentage of the maximum capacity managed by the valve	■
	CH-Superheat set	superheat set point	■
	CH-Prop. gain	PID proportional factor	■
	CH-Integral time	integral time for superheat control	■
Advanced I	SH dead zone	dead zone for PID control	-
	Derivative time	PID derivative time	□
	CH-Low Superheat	low superheat value	□
	LOP Cool Mode	temperature at minimum operating pressure (LOP) in CH mode	□
	MOP Cool Mode	temperature at maximum operating pressure (MOP) in CH mode	□
	Low SH int. time	integral time for low superheat control	-
	LOP integral time	integral time for low evaporation pressure (LOP) control	-
	MOP integral time	integral time for high evaporation pressure (MOP) control	-
	Alarms del. Low SH	low superheat alarm delay	-
	Alarms del. LOP	low evaporation pressure (LOP) alarm delay	-
Alarms del. MOP	high evaporation pressure (MOP) alarm delay	-	
MOP startup delay	MOP delay time when starting control	-	
Advanced II	EEV mode man.	enable/disable manual valve positioning	-
	Requested steps	required motor position in manual control	-
	BlockedValve check	time after which the valve is considered as being blocked	-
	EVD probes type	type of sensors used	-
	S2-Pt1000 calib.	calibration index for PT1000 sensor	-
	Probes offset S1	correction of S1	-
	Probes offset S2	correction of S2	-
	Probes offset S3	correction of the lower limit of S3	-
	Al. delay probe err.	probe error alarm delay	-
	Open relais low SH	enable/disable relay opening following low superheat	-
Open relais MOP	enable/disable relay opening following MOP	-	
Valve alarm	enable/disable valve alarm	□	

System	Minimum steps	minimum control steps	-
	Maximum steps	maximum control steps	-
	Closing steps	steps completed in total closing	-
	Standby steps	number of valve standby steps	-
	Steprate	motor speed	-
	Phase current	peak current per phase	-
	Still current	current with the motor off	-
	Duty cycle	motor duty cycle	-
Global parameters (Fig. 3.21)			
Refrigerant	number indicating the type of refrigerant used	■	
Valve type	number that defines the type of electronic valve used	■	
S1 probe limitsMin barg	'zero' scale for pressure sensor on input S1	■	
S1 probe limitsMax barg	end scale for pressure sensor on input S1	■	
Stand alone	enable StandAlone	■	
Go ahead	enable restart following error	<input type="checkbox"/>	

READ

Parameter name	Description
System measurements (Fig. 3.21)	
EEV opening	valve opening as a %
EEV position	calculated electronic expansion valve opening position
Act. SH set	current superheat set point
Superheat	superheat value measured
Ev. probe press.	evaporation pressure value measured by sensor
Ev. probe sat. temp	saturated gas temperature value calculated in the evaporator
Suction temp.	compressor suction temperature value measured by sensor
Digital variables (Fig. 3.21)	
Alarm Low SH	active in low superheat conditions
Alarm MOP timeout	active in conditions with excessive evaporation pressure
Alarm LOP timeout	active in conditions with insufficient evaporation pressure
EEV not closed	active due to failed valve closing
Low SH status	active when in low superheat control status
MOP status	active when in maximum evaporation pressure control status
LOP status	active when in minimum evaporation pressure control status
Alarm Eeprom err.	active following an EEPROM memory error
Alarm probe err.	active following an error on the signal from the probe
Digital input 1	status of digital input 1
DOUT2	output relay control signal

3.5.3 EVD4_UI user interface

The EVD4_UI user interface is based on the CAREL supervisor protocol and is designed for the easy and intuitive reading or configuration of the control parameters. The program can be started in different configurations so as to display the set of parameters that is suitable for the type of installation the EVD4 is used in; to do this, make the connection using the name of the required configuration.

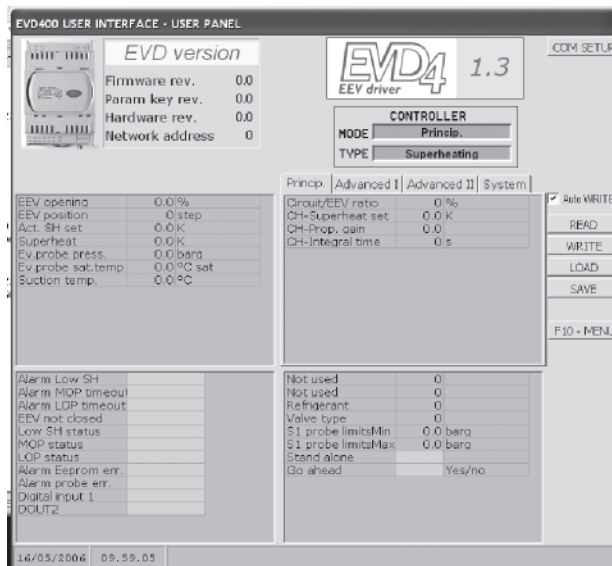

Fig. 3.21

The interface configuration for the 'positioner' function is shown in Fig. 3.21 and is activated by making the "EVD4_UI stand alone" connection, as described in APPENDIX I "INSTALLING AND USING THE EVD4_UI PROGRAM".

3.5.4 Start-up

After having connected the EVD4, as described in 3.5.1, connect the service serial port to a PC via the special converter and configure the parameters and the address using according to the application and/or systems used. The controller is already enabled; to switch off the EVD4, disable the Stand-alone variable or modify the status of digital input D1 (Fig. 2.1) and run the supervisor program (i.e. PlantVisor) to monitor the system.

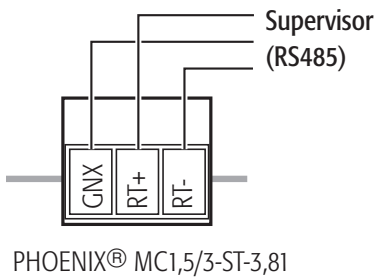

Fig. 3.22

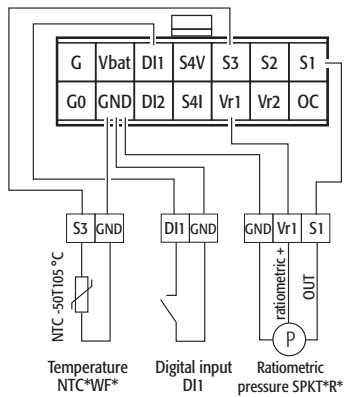

Fig. 3.23

For other types of probes or connections, change the value of the "EVD probes type" parameter and see technical leaflet.

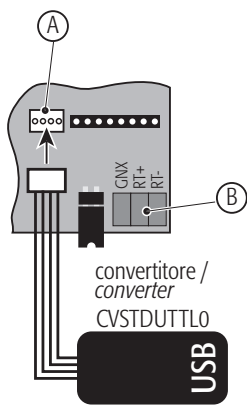

Fig. 3.24

Key:
 A Service serial port
 B Main serial port

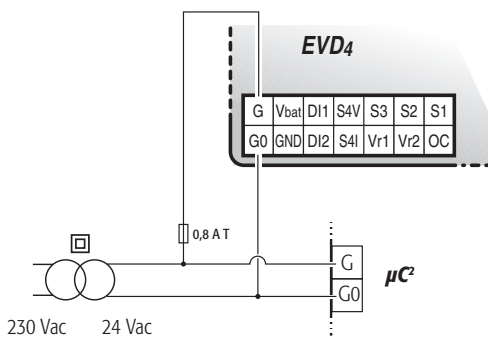

Fig. 3.25

3.6 Application with Modbus® protocol (EVD0001460) via RS485

3.6.1 Connections

Communication: connect GNX, RT+ and RT- to the corresponding ends of the RS485 serial interface connected to the pCO controller (see the pCO sistema manual) (Fig. 3.22).

Configuration: Connect the converter (CVSTDUTTLO or CVSTD0TTLO) to the service serial port and to a PC with USB or RS232 serial port (Fig. 3.18).

Power supply: connect G and G0 to the 24 Vac power supply (Fig. 3.19)

Valve: connect the valve according to the type set for the "Valve type" parameter (Fig. 3.20).

Probes: Connect the ratiometric pressure sensors and NTC temperature sensors to S1 and S3 respectively.

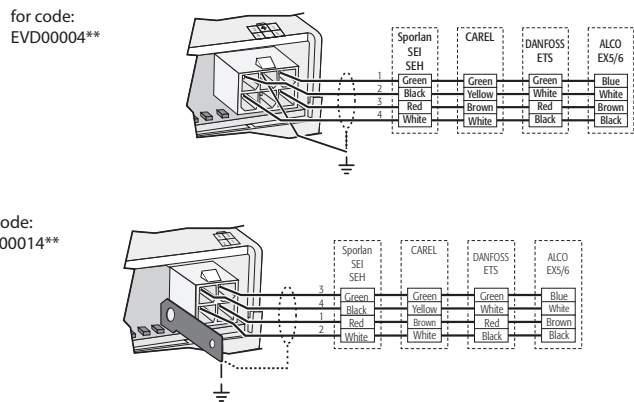

Fig. 3.26

3.5.2 List of parameters

Below is the list of parameters visible from the EVD4-UI, divided into write and read; the meaning of each is detailed in APPENDIX II, while APPENDIX III shows a list of the values of the reference parameters in relation to certain applications. Key: ■ = Main parameters required to start operation; □ = Secondary parameters required for optimum operation; - = Advanced parameters.

WRITE

Mode	Parameter name	Parameter description	
Mode dependent parameters (Fig. 3.21)			
Main	Circuit/EEV ratio	percentage of the maximum capacity managed by the valve	■
	CH-Superheat set	superheat set point	■
	CH-Prop. gain	PID proportional factor	■
	CH-Integral time	integral time for superheat control	■
Advanced I	SH dead zone	dead zone for PID control	-
	Derivative time	PID derivative time	□
	CH-Low Superheat	low superheat value	□
	LOP Cool Mode	temperature at minimum operating pressure (LOP) in CH mode	□
	MOP Cool Mode	temperature at maximum operating pressure (MOP) in CH mode	□
	Low SH int. time	integral time for low superheat control	-
	LOP integral time	integral time for low evaporation pressure (LOP) control	-
	MOP integral time	integral time for high evaporation pressure (MOP) control	-
	Alarms del. Low SH	low superheat alarm delay	-
	Alarms del. LOP	low evaporation pressure (LOP) alarm delay	-
	Alarms del. MOP	high evaporation pressure (MOP) alarm delay	-
	MOP startup delay	MOP delay time when starting control	-
Advanced II	EEV mode man.	enable/disable manual valve positioning	-
	Requested steps	required motor position in manual control	-
	BlockedValve check	time after which the valve is considered as being blocked	-
	EVD probes type	type of sensors used	-
	S2-Pt1000 calib.	calibration index for PT1000 sensor	-
	Probes offset S1	correction of S1	-
	Probes offset S2	correction of S2	-
	Probes offset S3	correction of the lower limit of S3	-
	Al. delay probe err.	probe error alarm delay	-
	Open relais low SH	enable/disable relay opening following low superheat	-
Open relais MOP	enable/disable relay opening following MOP	-	
Valve alarm	enable/disable valve alarm	□	
System	Minimum steps	minimum control steps	-
	Maximum steps	maximum control steps	-
	Closing steps	steps completed in total closing	-
	Standby steps	number of valve standby steps	-
	Steprate	motor speed	-
	Phase current	peak current per phase	-
	Still current	current with the motor off	-
	Duty cycle	motor duty cycle	-
Global parameters (Fig. 3.21)			
	Refrigerant	number indicating the type of refrigerant used	■
	Valve type	number that defines the type of electronic valve used	■
	S1 probe limitsMin barg	'zero' scale for pressure sensor on input S1	■
	S1 probe limitsMax barg	end scale for pressure sensor on input S1	■
	Stand alone	enable StandAlone	■
	Go ahead	enable restart following error	□

READ

Parameter name	Description
	System measurements (Fig. 3.21)
EEV opening	valve opening as a %
EEV position	calculated electronic expansion valve opening position
Act. SH set	current superheat set point
Superheat	superheat value measured
Ev. probe press.	evaporation pressure value measured by sensor
Ev. probe sat. temp	saturated gas temperature value calculated in the evaporator
Suction temp.	compressor suction temperature value measured by sensor
	Digital variables (Fig. 3.21)
Alarm Low SH	active in low superheat conditions
Alarm MOP timeout	active in conditions with excessive evaporation pressure
Alarm LOP timeout	active in conditions with insufficient evaporation pressure
EEV not closed	active due to failed valve closing
Low SH status	active when in low superheat control status
MOP status	active when in maximum evaporation pressure control status
LOP status	active when in minimum evaporation pressure control status
Alarm Eeprom err.	active following an EEPROM memory error
Alarm probe err.	active following an error on the signal from the probe
Digital input 1	status of digital input 1
DOUT2	output relay control signal

3.6.3 Communication protocols

The protocol is implemented according to the envisaged specifications so that the device belongs to the BASIC class, with the possibility of setting some parameters (REGULAR class).

	Value	Default
Address	From 1 to 247	1
Broadcast	Detect messages with 0	---
Baudrate	4800, 9600, 19200	19200
Parity	None, even, odd	none
Mode	RTU	
Interface	RS485	

Setting the UNICAST address

The Modbus address can be selected using the "EVD4_UI Address" connection as described in "Appendix I – Installing and using the EVD4-UI program", within the envisaged range. Values from 248 to 255 are reserved. If set to one of these values or 0, the FW sets the default value without modifying the parameter in the E2prom. After setting the new value, the device needs to be switched off and on again to make it effective.

Setting the BROADCAST address

Broadcast messages (with address 0) can be sent, and will be write-only messages. The command will be executed, if possible, without any response.

Parity selection mode

The parity is selected using the same program for setting the "EVD4_UI Address", as described in "Appendix I – Installing and using the EVD4-UI program", setting bit 1.2 of parameter CfgProt. Specifically:

CfgProt	Bit0	Bit1	Bit2	ModBus parity
1	1	0	0	None
3	1	1	0	Even
5	1	0	1	Odd

If no parity is selected, the number of stop bits will be 2 (default). After setting the new value, the device needs to be switched off and on again to make it effective.

Modbus messages

The Modbus messages codes are:

- 01 Read Coil Status
- 02 Read Input Status

These two messages have the same effect as reading digital variables.

- 03 Read Holding Registers
- 04 Read Input Registers

These two messages have the same effect as reading analogue/integer variables.

- 05 Force Single Coil
- 06 Preset Single Register
- 15 Force Multiple Coils
- 16 Preset Multiple Regs

A maximum number of 8 variables can be written with commands 15 and 16.

- 17 Report Slave ID

The message is structured as follows, as regards the data part:

Description	Type
ON status Run indicator: 0xFF or 0x00 depending on whether the device is actively controlling or not	byte
Peripheral type: high part and low part of the device code	word
Firmware release: high part and low part of the FW release	word
Reserved	word
Hardware release: high part and low part of the HW release	word
Reserved	word
Reserved	word
Reserved	word

Error messages (exceptions)**01 ILLEGAL FUNCTION**

The requested function is not available on the device.

02 ILLEGAL DATA ADDRESS

The requested address, or one of the requested addresses for a read command is invalid. This message will be returned as a response whenever attempting to read an unavailable address.

03 ILLEGAL DATA VALUE

Whenever attempting to write a read-only variable, or alternatively when attempting to individually write a coil with values that are not envisaged by the protocol (other than FF00 and 0000).

NOTE: in all other cases, the device does not check the values of the variables that can be written, but simply whether the message is valid, using the CRC; the correctness of the values is checked by the supervisor.

06 SLAVE DEVICE BUSY

If for example the command involves executing actions that require a certain time to be completed. In this case the supervisor must send the command again subsequently.

3.6.4 Supervisor variable mapping

The supervisor variables have been grouped into two main classes: read-only, which are reserved the lower ModBus addresses, and read/write, according to the following table:

MODBUS VARIABLES (EVD0001460)

MODBUS TYPE	MODBUS INDEX	CAREL TYPE
REGISTER	1 to 16	ANALOGUE (R ONLY)
REGISTER	50 to 86	ANALOGUE (R/W)
REGISTER	128 to 150	INTEGER (R ONLY)
REGISTER	163 to 231	INTEGER (R/W)
COIL	1 to 20	DIGITAL (R ONLY)
COIL	51 to 84	DIGITAL (R/W)

The correspondence between the Carel supervisor addresses of the variables and the ModBus device addresses is as follows (for a complete description of the parameter corresponding to the variables, see "APPENDIX II DESCRIPTION OF THE PARAMETERS"):

Carel type	R/W	Spv address	ModBus type	R/W	ModBus address
A	R	4	REGISTER	R	1
A	R	5	REGISTER	R	2
A	R	6	REGISTER	R	3
A	R	7	REGISTER	R	4
A	R	8	REGISTER	R	5
A	R	9	REGISTER	R	6
A	R	10	REGISTER	R	7
A	R	13	REGISTER	R	8
A	R	14	REGISTER	R	9
A	R	15	REGISTER	R	10
A	R	16	REGISTER	R	11
A	R	17	REGISTER	R	12
A	R	18	REGISTER	R	13
A	R	37	REGISTER	R	14
A	R	38	REGISTER	R	15
A	R	39	REGISTER	R	16
A	R/W	1	REGISTER	R/W	50
A	R/W	2	REGISTER	R/W	51
A	R/W	3	REGISTER	R/W	52
A	R/W	11	REGISTER	R/W	53
A	R/W	12	REGISTER	R/W	54
A	R/W	21	REGISTER	R/W	55
A	R/W	22	REGISTER	R/W	56
A	R/W	23	REGISTER	R/W	57
A	R/W	24	REGISTER	R/W	58
A	R/W	25	REGISTER	R/W	59
A	R/W	26	REGISTER	R/W	60
A	R/W	27	REGISTER	R/W	61
A	R/W	28	REGISTER	R/W	62
A	R/W	29	REGISTER	R/W	63
A	R/W	30	REGISTER	R/W	64
A	R/W	31	REGISTER	R/W	65
A	R/W	32	REGISTER	R/W	66
A	R/W	33	REGISTER	R/W	67
A	R/W	34	REGISTER	R/W	68
A	R/W	35	REGISTER	R/W	69
A	R/W	36	REGISTER	R/W	70
A	R/W	40	REGISTER	R/W	71
A	R/W	43	REGISTER	R/W	72
A	R/W	44	REGISTER	R/W	73
A	R/W	45	REGISTER	R/W	74
A	R/W	46	REGISTER	R/W	75
A	R/W	47	REGISTER	R/W	76

A	R/W	48	REGISTER	R/W	77
A	R/W	49	REGISTER	R/W	78
A	R/W	50	REGISTER	R/W	79
A	R/W	51	REGISTER	R/W	80
A	R/W	52	REGISTER	R/W	81
A	R/W	53	REGISTER	R/W	82
A	R/W	54	REGISTER	R/W	83
A	R/W	55	REGISTER	R/W	84
A	R/W	56	REGISTER	R/W	85
A	R/W	57	REGISTER	R/W	86

I	R	12	REGISTER	R	128
I	R	15	REGISTER	R	129
I	R	21	REGISTER	R	130
I	R	66	REGISTER	R	131
I	R	77	REGISTER	R	132
I	R	90	REGISTER	R	133
I	R	91	REGISTER	R	134
I	R	92	REGISTER	R	135
I	R	93	REGISTER	R	136
I	R	94	REGISTER	R	137
I	R	95	REGISTER	R	138
I	R	96	REGISTER	R	139
I	R	100	REGISTER	R	140
I	R	105	REGISTER	R	141
I	R	106	REGISTER	R	142
I	R	107	REGISTER	R	143
I	R	108	REGISTER	R	144
I	R	109	REGISTER	R	145
I	R	110	REGISTER	R	146
I	R	111	REGISTER	R	147
I	R	112	REGISTER	R	148
I	R	113	REGISTER	R	149
I	R	114	REGISTER	R	150

I	R/W	1	REGISTER	R/W	163
I	R/W	2	REGISTER	R/W	164
I	R/W	3	REGISTER	R/W	165
I	R/W	4	REGISTER	R/W	166
I	R/W	5	REGISTER	R/W	167
I	R/W	6	REGISTER	R/W	168
I	R/W	7	REGISTER	R/W	169
I	R/W	8	REGISTER	R/W	170
I	R/W	9	REGISTER	R/W	171
I	R/W	10	REGISTER	R/W	172
I	R/W	11	REGISTER	R/W	173
I	R/W	13	REGISTER	R/W	174
I	R/W	14	REGISTER	R/W	175
I	R/W	16	REGISTER	R/W	176
I	R/W	17	REGISTER	R/W	177
I	R/W	18	REGISTER	R/W	178
I	R/W	19	REGISTER	R/W	179
I	R/W	20	REGISTER	R/W	180
I	R/W	22	REGISTER	R/W	181
I	R/W	23	REGISTER	R/W	182
I	R/W	24	REGISTER	R/W	183
I	R/W	25	REGISTER	R/W	184
I	R/W	26	REGISTER	R/W	185
I	R/W	27	REGISTER	R/W	186
I	R/W	28	REGISTER	R/W	187
I	R/W	29	REGISTER	R/W	188
I	R/W	30	REGISTER	R/W	189
I	R/W	31	REGISTER	R/W	190
I	R/W	33	REGISTER	R/W	191
I	R/W	34	REGISTER	R/W	192
I	R/W	35	REGISTER	R/W	193
I	R/W	36	REGISTER	R/W	194
I	R/W	37	REGISTER	R/W	195
I	R/W	38	REGISTER	R/W	196
I	R/W	39	REGISTER	R/W	197
I	R/W	40	REGISTER	R/W	198
I	R/W	41	REGISTER	R/W	199
I	R/W	42	REGISTER	R/W	200
I	R/W	43	REGISTER	R/W	201
I	R/W	44	REGISTER	R/W	202
I	R/W	45	REGISTER	R/W	203
I	R/W	46	REGISTER	R/W	204
I	R/W	47	REGISTER	R/W	205
I	R/W	48	REGISTER	R/W	206
I	R/W	49	REGISTER	R/W	207
I	R/W	50	REGISTER	R/W	208
I	R/W	51	REGISTER	R/W	209
I	R/W	52	REGISTER	R/W	210
I	R/W	53	REGISTER	R/W	211
I	R/W	54	REGISTER	R/W	212
I	R/W	55	REGISTER	R/W	213
I	R/W	56	REGISTER	R/W	214
I	R/W	57	REGISTER	R/W	215

I	R/W	58	REGISTER	R/W	216
I	R/W	59	REGISTER	R/W	217
I	R/W	60	REGISTER	R/W	218
I	R/W	61	REGISTER	R/W	219
I	R/W	62	REGISTER	R/W	220
I	R/W	63	REGISTER	R/W	221
I	R/W	67	REGISTER	R/W	222
I	R/W	68	REGISTER	R/W	223
I	R/W	69	REGISTER	R/W	224
I	R/W	70	REGISTER	R/W	225
I	R/W	71	REGISTER	R/W	226
I	R/W	72	REGISTER	R/W	227
I	R/W	73	REGISTER	R/W	228
I	R/W	74	REGISTER	R/W	229
I	R/W	75	REGISTER	R/W	230
I	R/W	76	REGISTER	R/W	231

D	R	17	COIL	R	1
D	R	18	COIL	R	2
D	R	19	COIL	R	3
D	R	20	COIL	R	4
D	R	21	COIL	R	5
D	R	22	COIL	R	6
D	R	24	COIL	R	7
D	R	41	COIL	R	8
D	R	42	COIL	R	9
D	R	43	COIL	R	10
D	R	44	COIL	R	11
D	R	45	COIL	R	12
D	R	46	COIL	R	13
D	R	47	COIL	R	14
D	R	49	COIL	R	15
D	R	50	COIL	R	16
D	R	51	COIL	R	17
D	R	52	COIL	R	18
D	R	53	COIL	R	19
D	R	64	COIL	R	20

D	R/W	1	COIL	R/W	51
D	R/W	2	COIL	R/W	52
D	R/W	3	COIL	R/W	53
D	R/W	4	COIL	R/W	54
D	R/W	5	COIL	R/W	55
D	R/W	9	COIL	R/W	56
D	R/W	10	COIL	R/W	57
D	R/W	11	COIL	R/W	58
D	R/W	12	COIL	R/W	58
D	R/W	23	COIL	R/W	60
D	R/W	25	COIL	R/W	61
D	R/W	26	COIL	R/W	62
D	R/W	27	COIL	R/W	63
D	R/W	28	COIL	R/W	64
D	R/W	29	COIL	R/W	65
D	R/W	30	COIL	R/W	66
D	R/W	31	COIL	R/W	67
D	R/W	32	COIL	R/W	68
D	R/W	33	COIL	R/W	69
D	R/W	34	COIL	R/W	70
D	R/W	35	COIL	R/W	71
D	R/W	36	COIL	R/W	72
D	R/W	58	COIL	R/W	73
D	R/W	59	COIL	R/W	74
D	R/W	60	COIL	R/W	75
D	R/W	61	COIL	R/W	76
D	R/W	62	COIL	R/W	77
D	R/W	63	COIL	R/W	78
D	R/W	65	COIL	R/W	79
D	R/W	66	COIL	R/W	80
D	R/W	67	COIL	R/W	81
D	R/W	68	COIL	R/W	82
D	R/W	69	COIL	R/W	83
D	R/W	70	COIL	R/W	84

3.6.5 EVD4_UI user interface

The EVD4_UI user interface is based on the CAREL supervisor protocol and is designed for the easy and intuitive reading or configuration of the control parameters. The program can be started in different configurations so as to display the set of parameters that is suitable for the type of installation the EVD4 is used in; to do this, make the connection using the name of the required configuration.

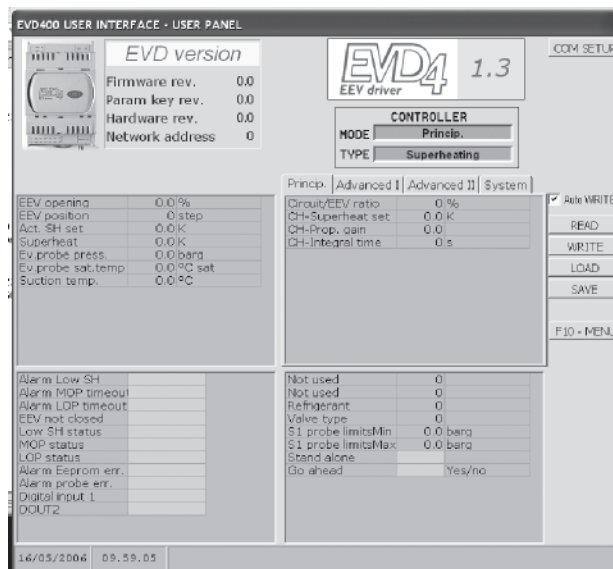

Fig. 3.27

The interface configuration for the 'positioner' function is shown in Fig. 3.21 and is activated by making the "EVD4_UI stand alone" connection, as described in APPENDIX I "INSTALLING AND USING THE EVD4_UI PROGRAM".

3.6.6 Start-up

After having connected the EVD4, as described in 3.5.1, connect the service serial port to a PC via the special converter and configure the parameters and the address using according to the application and/or systems used. The controller is already enabled; to switch off the EVD4, disable the Stand-alone variable or modify the status of digital input D1 (Fig. 2.1) and run the supervisor program (i.e. PlantVisor) to monitor the system.

4. TECHNICAL AND CONSTRUCTIONAL SPECIFICATIONS

Probe connections (Default)

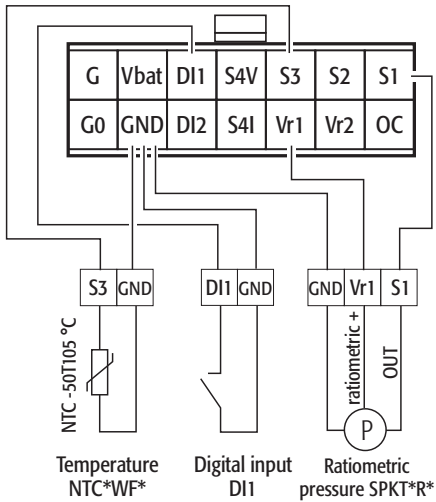

Fig. 4.1

Other connections

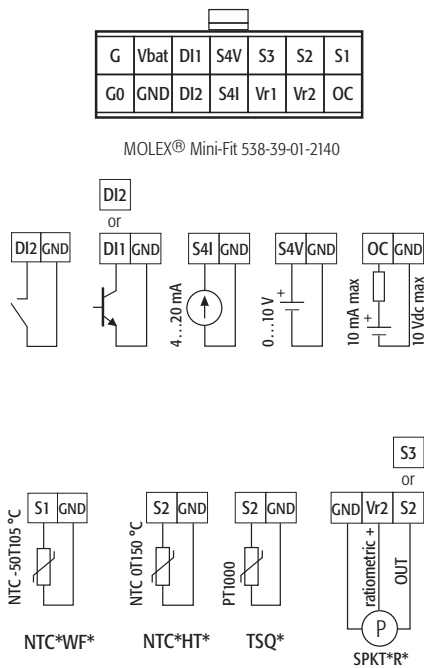

Fig. 4.2

Installation and storage specifications

Operating conditions	-10T60°C, < 90% RH non-condensing
Storage conditions	-20T70°C, < 90% RH non-condensing
Index of protection	IP20
Wire cross-section	0.5 to 2.5 mm ²
Dimensions	70 x 110 x 60
PTI of insulating materials	250 V
Protection against electric shock	to be integrated into class I and/or II equipment
Degree of environmental pollution	normal
Resistance to heat and fire	category D
Immunity against voltage surges	category 1
Surface temperature limits	as per the operating conditions
Assembly	on DIN rail
Case width	4 modules
Disposal	the module is made up of metal and plastic parts. These must be disposed of according to the waste disposal local legislation in force

Motor control

The controller works with two-pole stepper motors (Fig. 1). It works with a theoretical sinusoidal waveform, in micro-steps and with speeds from 5 to 1000 steps; the current and the control speed effectively achievable depend on the resistance and the inductance of the motor windings. If the driver is connected to a pCO, it receives all the individual operating parameters for the motor from the pCO controller, if, on the other hand, it is used in stand-alone mode or with the microchiller controller, only one parameter needs to be set, taken from Table 5, according to the model of motor used (see Table 5). The controller can manage motors with maximum positions of up to 32000 steps. For connection use 4-wire shielded cables, AWG18/22, max. length 9.5 m. The shield should be connected to the closest possible earth point in the panel.

Power supply

Power supply: 20 to 28 Vac or 20 to 30 Vdc 50/60 Hz to be protected by external 0.8 A fuse, type T. Use a class II safety transformer rated to at least 20 VA. Average current input at 24 Vac: 60 mA with the motor not operating (control logic only); 240 mA with CAREL motor operating (240 mA peak at 18 Ω). Emergency power supply: if the optional EVBAT00200/300 module is installed, power supply is guaranteed to the controller for the time required to close the valve.

Inputs and outputs

Analogue inputs (*)

input	type	CAREL code
S1-S3:	NTC (-50T105 °C)	NTC*WF*
	Raziom. (0.5...4.5 Vdc)	SPKT*R*
S2:	NTC (0T150 °C)	NTC*HT*
	Raziom. (0.5...4.5 Vdc)	SPKT*R*
S4:	Pt1000	TSQ*
	current at 100 Ω	4...20 mA
	voltage at 1 kΩ	0...10 V

Digital inputs ID1 and ID2: controlled by voltage-free contact or transistor, have a no-load voltage of 5 V and deliver 5 mA short-circuited.

Digital output OC: open-collector transistor; max no-load voltage 10 V, max current 10 mA.

Relay output: normally open contact; 5 A 250 Vac resistive load; 2 A 250 Vac, inductive load (PF= 0.4).



(*) **WARNING!** All analogue inputs except for S4 V, the digital I/O and the serial port (not optically-isolated) refer to the GND earth, (Fig. 3) and consequently the even temporary application of voltages higher than ±5 V to these connectors may cause irreversible damage to the controller. Input S4 V can tolerate voltages up to 30 V. As GND is the common earth for all the inputs, this should be replicated on the terminal block with low-resistance connections for each input used. The GNX earth for the serial connection is electrically connected to the GND earth. The product complies with Directive 89/336/EEC (EMC). Contact CAREL if specific disturbance occurs in the configuration used. If the connection to the motor is made using a shielded cable, the cable shield and the channel marked by the earth symbol on the 6-pin connector must be earthed as near as possible to the EVD400.

Valve table

n°	Model	Step min	Step max	Step close	Step/s speed	mA pk	mA hold	% duty
0	CAREL E2V*	50	480	500	100	450	100	30
1	Sporlan SEI 0.5-20	100	1596	3600	200	200	50	70
2	Sporlan SEI 30	200	3193	3600	200	200	50	70
3	Sporlan SEH 50-250	400	6386	7500	200	200	50	70
4	Alco EX5-EX6	100	750	750	450	400	100	70
5	Alco EX7	250	1600	1600	330	750	250	70
6	Alco EX8 330 step/s	250	2600	2600	330	800	500	70
7	Alco EX8 500 step/s	250	2600	2600	500	800	500	70
8	Danfoss ETS-25/50	200	2625	2700	120	140	75	70
9	Danfoss ETS-100	300	3530	3600	120	140	75	70
10	CAREL E2V*P	50	380	400	100	450	100	30
11	Danfoss ETS-250/400	350	3810	3900	120	140	75	70

Table of refrigerants (consult the electronic expansion valve technical documentation to check the complete valve-driver system compatibility with the chosen refrigerant)

n°	"R" number	operating temperature	n°	"R" number	operating temperature
1	R22	-40T60	7	R290	-50T96
2	R134a	-40T60	8	R600	-50T90
3	R404a	-40T60	9	R600a	-50T90
4	R407c	-40T60	10	R717	-60T70
5	R410a	-40T60	11	R744	-50T31
6	R507c	-40T60	12	R728	-20T-145
			13	R1270	-60T90

5. TROUBLESHOOTING

The following table lists a series of possible malfunctions that may occur when starting and operating the driver and the electronic valve. These cover the most common problems and are provided with the aim of offering an initial response for resolving the problem.

Problem	Cause	Solution
Liquid returns to the compressor during the operation of the controller	The probes measure an incorrect superheat value	Check that the pressure and the temperature measured are correct and that the position of the probes is correct. Check the correct range of the pressure probe. Check the correct electrical connections of the probes.
	The type of refrigerant set is incorrect	Check and correct the parameter relating to the type of refrigerant.
	The type of valve set is incorrect	Check and correct the valve type parameter.
	The valves are not connected correctly (reversed) and are open	Check the movement of the valve by setting manual control and closing and opening it completely. If reversed, check the connections.
	The superheat set point is too low	Increase the superheat set point.
	Low superheat protection ineffective	Increase the low superheat threshold and/or decrease the low superheat integral time.
	Valve blocked open	Check if the superheat is low on one or more showcases, with the valve position permanently at 0. Use manual control to close and open it completely. If the superheat is always low, check the electrical connections and/or replace the valve.
Liquid returns to the compressor only after defrosting (for showcases only)	The "Circuit/EEV ratio" parameter is too high on many showcases and the control set point is often reached (for showcases only)	Try lowering the value of the "Circuit/EEV ratio" parameter on all the utilities, checking that there are no repercussions on the control temperature.
	Before becoming stable, the superheat value is very low for a few some minutes	Increase the low superheat threshold to at least 2 °C higher than the (low) superheat value and/or decrease the low superheat integral time, which must always be greater than zero.
	The superheat never reaches very low values	Set more reactive parameters (increase the proportional factor, increase the integral time, increase the differential time) to bring forward the closing of the valve even when the superheat is greater than the set point.
	Multiple showcases defrost at the same time	Stagger the start defrost times. If this is not possible, if the conditions described in the two previous points are not present, increase the superheat set point for the showcases involved.
Liquid returns to the compressor only when starting the controller (after being OFF)	The valve is greatly oversized	Set the key11 parameter to 24717, valve type to 99 (custom), disable the extra steps in opening parameter and reduce the maximum valve steps parameter to a value that is 20% higher than the maximum valve position reached during normal control. The time taken to reach steady operation after defrosting will be longer.
	The "Circuit/EEV ratio" parameter is too high	Lower the value of the "Circuit/EEV ratio" parameter.
	The condensing pressure swings	Check that the condensing pressure is stable (maximum +/- 0.5bar from the set point). If not, try to stabilise the condensing pressure using the controller (e.g. disable the condensing pressure control and operate the fans at maximum speed, depending on the operating conditions of the installation).
	The superheat set point is too low	Increase the superheat set point, checking that the temperature of the unit remains low and reaches the control set point. If the situation improves, adopt this new set point, otherwise see the following points.
	The superheat also swings with the driver in manual control	Observe the average operating position of the valve, enable manual positioning and set the opening of the valve to the average value observed: if the swing persists, re-enable automatic operation and set more reactive parameters (increase the proportional factor, increase the integral time, increase the differential time).
The system swings	The superheat only swings with the driver in automatic control	Observe the average operating position of the valve, enable manual positioning and set the opening of the valve to the average value observed: if the swing stops, re-enable automatic operation and set less reactive parameters (decrease the proportional factor, increase the integral time).
	Bubbles of air can be seen in the liquid indicator upstream of the expansion valve or adequate subcooling is not guaranteed	Charge the circuit with refrigerant.
	MOP protection disabled	Activate the MOP protection, setting the threshold to the required saturated evaporation temperature (high evaporation temperature limit for the compressors) and the MOP integral time to a value greater than 0 (recommended 4sec).
During start-up with high evaporator temperature, the evaporation pressure is high	MOP protection ineffective	Make sure that the MOP threshold is at the required saturated evaporation temperature (high evaporation temperature limit for the compressors) and decrease the value of the MOP integral time.
	Excessive refrigerant charge for the system (for showcases only)	Apply a "soft start" technique by activating the utilities one at a time or in small groups. If this is not possible, decrease the values of the MOP thresholds.
During start-up the unit switches off due to low pressure (units with on-board compressor only)	The "Circuit/EEV ratio" parameter is too low	Increase the value of the "Circuit/EEV ratio" parameter.
	The driver is not set correctly in STAND ALONE	Check that the strand alone parameter is activated.
	The driver digital input is not connected correctly	Check the connection of the digital input.
	LOP protection disabled	Activate the LOP protection by setting the threshold to the required saturated evaporation temperature (between the operating temperature and the calibration of the low pressure switch) and the LOP integral time to a value greater than 0 (recommended 4sec)
	LOP protection ineffective	Make sure that the LOP threshold is at the required saturated evaporation temperature (between the operating temperature and the calibration of the low pressure switch) and decrease the value of the LOP integral time.
	Solenoid blocked	Check that the solenoid opens correctly, check the electrical connections and the operation of the relay.
	Insufficient refrigerant	Check that there are no bubbles of air in the liquid indicator upstream of the expansion valve. Check that the subcooling is suitable (greater than 5°C). Charge the circuit.
The unit switches off due to low pressure during control (units with on-board compressor only)	Valve blocked closed	Use manual control to close and open the valve completely. If the superheat remains high, check the electrical connections and/or replace the valve.
	LOP protection disabled	Activate the LOP protection by setting the threshold to the required saturated evaporation temperature (between the operating temperature and the calibration of the low pressure switch) and the LOP integral time to a value greater than 0 (recommended 4sec)
	LOP protection ineffective	Make sure that the LOP threshold is at the required saturated evaporation temperature (between the operating temperature and the calibration of the low pressure switch) and decrease the value of the LOP integral time.
	Solenoid blocked	Check that the solenoid opens correctly, check the electrical connections and the operation of the relay.
	Insufficient refrigerant	Check that there are no bubbles of air in the liquid indicator upstream of the expansion valve. Check that the subcooling is suitable (greater than 5 °C). Charge the circuit.
The showcase does not reach the set temperature, despite the valve opening to the maximum (for showcases only)	Valve blocked closed	Use manual control to close and open the valve completely. If the superheat remains high, check the electrical connections and/or replace the valve.
	Solenoid blocked	Check that the solenoid opens correctly, check the electrical connections and the operation of the relay.
	Insufficient refrigerant	Check that there are no bubbles of air in the liquid indicator upstream of the expansion valve. Check that the subcooling is suitable (greater than 5 °C). Charge the circuit.
The showcase does not reach the set temperature, and the position of the valve is always to 0 (for showcases only)	Valve blocked closed	Use manual control to close and open the valve completely. If the superheat remains high, check the electrical connections and/or replace the valve.
	The driver is not set correctly in STAND ALONE	Check that the strand alone parameter is activated.
	The driver digital input is not connected correctly	Check the connection of the digital input.

APPENDIX I. INSTALLING AND USING THE EVD4-UI PROGRAM

Below is a description of how to install and use the EVD4-UI configuration and monitoring program

I.I Installation

To install the program:

- download the required EVD4_UI*.zip file from <http://KSA.Carel.com>;
- copy the contents of the EVD4_UI*.zip file to the required path on the PC (e.g.: C:\Program Files);
- the first time that the program is used, edit the Destination item under the Link properties by entering the path used on the PC:

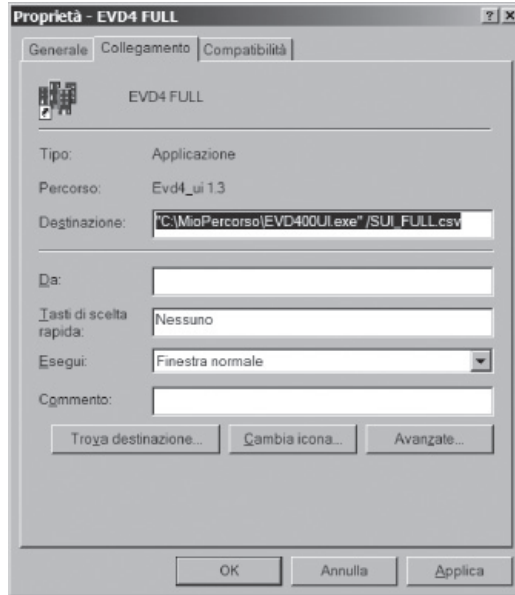

Fig. 1

I.II Preparing the connections

Connect the CVSTDUTTLO converter to the EVD⁴ controller, as explained in § 2.5.

I.III Preparing the user interface

The program does not require installation; simply copy the entire contents of the distribution directory to the required location on the hard disk. The program cannot run from the CD as it requires write access to the configuration files.

Open the IN\EVD400UI.INI file from the path where EVD4_UI.exe is located and make sure that the Paddr parameter is set to 1.

Start the EVD4_UI program using the shortcut icon to the application (see VII Configurations available) and not the EVD4_UI.exe file, then press **[COM SETUP]** and set:

- Port = COM address of the serial port used to connect the CVSTD*TTLO
- Baud Rate = 4800
- Parity = NO PARITY
- Byte Size = 8
- Stop Bits = 1

Press **[SAVE]**.

Now, if the converter is connected to an EVD⁴, image of the driver will be displayed in the top left and, the EVD version window will show the following data

- Firmware rev. = firmware version of the EVD⁴ connected
- Param key rev. = parameter key version (for future use)
- Hardware rev. = hardware version
- Network address = network address of the main serial port

I.IV Saving the data

Pressing **[SAVE]** will open a dialogue box to save the entire memory of the EVD⁴:

choose a path and enter a name with the extension *.CFG, then press **[Salva]**.

I.V Loading the data

Pressing will open a dialogue box to read a file with the extension *.CFG:

choose a file and press , all the data will be displayed in the various windows of the EVD400UI program.

To transfer the data to the EVD⁴ press , the Auto WRITE function in this case has no action

I.VI Modifying the parameters

To modify a numerical parameter:

- check the box containing the value of the parameter
- click the right mouse button
- set the new value
- ENTER

To reverse the value of a digital parameter (red or green rectangle):

- check the box containing the value of the parameter
- click the right mouse button

Meaning of the red or green rectangle:

- GREEN = FALSE or OFF or 0 or DISABLED, in relation to the meaning of the reference parameter
- RED = TRUE or ON or 1 or ENABLED, in relation to the meaning of the reference parameter

if the Auto WRITE checkbox is selected, the data is sent to EVD⁴ immediately after having been modified, otherwise, after having modified all the required data, press

I.VII Configurations available

The software used to install EVD4_UI is available in the following configurations:

- "EVD4_UI Address", to set the address of the EVD⁴
- "EVD4_UI Key", to program the key
- "EVD4_UI Stand Alone" to program the stand-alone EVD⁴
- "EVD4_UI MCH2" to program the EVD⁴ with μC^2
- "EVD4_U positioner" to use the EVD⁴ as a positioner with 4 to 20 mA or 0 to 10 Volt

This box is used to set the Driver+Valve system configuration values.

These parameters should be set and checked before activating the unit.

APPENDIX II. DESCRIPTION OF THE PARAMETERS

In this square the Driver+Valve system configuration values are set.
These parameters have to be set and checked before starting up the unit.

Key:

■ = Main parameters required to start operation;

□ = Secondary parameters required for optimum operation.

Parameter	PV address		Default EVD%40% and EVD%43%	Default EVD%41% and EVD%44%	Default EVD%42% and EVD%45%	Description UI	Meaning
µC ² off line	D	24	0	0	0	active when µC ² is not connected to EVD ⁴	The tLAN communication has been interrupted or has not been restored, see the WARNING in par. 3.1.1
100% capacity	D	26	0	0	0	active when the capacity of the circuit is 100%	µC ² has brought the capacity of the compressor to 100%, the information is sent to EVD ⁴ so as to preposition the electronic expansion valve
50% capacity	D	25	0	0	0	active when the capacity of the circuit is 50%	µC ² has brought the capacity of the compressor to 50%, the information is sent to EVD ⁴ so as to preposition the electronic expansion valve
Act. SH set	A	10	0	0	0	current superheat set point	This is equal to CH-Superheat set (or similar for HP or DF), corrected if necessary by the safety devices and/or the modulation, read-only
Alarm Eeprom error	D	42	0	0	0	active following an EEPROM memory error	Fault in the EEPROM memory, the system may request a GO AHEAD; contact the Carel technical service if the origin of the error is not clear
Alarm HiT asp	D	46	0	0	0	active in conditions with excessive suction temperature	The temperature measured by the EVD ⁴ probe has exceeded the threshold value set for the High superheat alarm threshold for a time greater than the Alarms delay High SH, check if the delay configured is suitable for the application
Alarm LOP timeout	D	45	0	0	0	active in conditions with insufficient evaporation pressure	Active in conditions with insufficient evaporation pressure, that is, when LOP is lower than the set threshold for LOP Cool Mode (or LOP Defr. Mode or LOP Heat Mode) for a time greater than the Alarms delay LOP, check if the delay configured is suitable for the application
Alarm Low Superheat	D	41	0	0	0	active in low superheat conditions	Active when the SH measured is lower than the set threshold for CH-Low Superheat (or similar for HP or DF) for a time greater than the Alarms delay Low SH, check if the timeout is suitable for the application
Alarm MOP timeout	D	44	0	0	0	active in conditions with excessive evaporation pressure	Active in conditions with excessive evaporation pressure, that is, when MOP is greater than the set threshold for MOP Cool Mode (or MOP Defr. Mode or MOP Heat Mode) for a time greater than the MOP delay, check if the timeout is suitable for the application
Alarm probe error	D	43	0	0	0	active following an error on the signal from the probe	The driver interprets a signal from the sensor that is outside of a determined range of operation as being a probe error; the interval depends on the type of probe and the input used, as described in table A. The system may request a GO AHEAD; contact the Carel technical service if the origin of the error is not clear
Alarms delay High SH	I	55	0	0	0	high superheat temperature alarm delay in CH mode	This is the time that passes from when High superheat alarm threshold is continuously exceeded to when the user wants the error to be displayed and/or managed
Alarms delay LOP	I	53	60	60	120	low evaporation pressure (LOP) alarm delay	This is the time that passes from when the superheat temperature is continuously less than the value set for LOP cool mode (or LOP Defr. Mode or LOP Heat Mode) to when the user wants the error to be displayed and/or managed
Alarms delay Low SH	I	52	60	60	120	low superheat alarm delay	This is the time that passes from when the value of superheat is continuously less than the value set for CH-Low Superheat (or similar for HP or DF) to when the user wants the error to be displayed and/or managed
Alarms delay MOP	I	54	0	0	0	high evaporation pressure (MOP) alarm delay	This is the time that passes from when the superheat temperature is continuously greater than the value set for MOP cool mode (or MOP Defr. Mode or MOP Heat Mode) to when the user wants the error to be displayed and/or managed
Alarms delay probe error	I	48	10	10	10	probe error alarm delay	This is the time that passes from when the Alarm probe error is continuously active to when the user wants the error to be displayed and/or managed
Aux reg.	I	56	0	0	0	type of auxiliary PID control	"0 = no auxiliary control1 = enable high condensing temperature protection (see Hi Tcond. protection)"
Aux. probe config.	I	69				auxiliary probe configuration	"Configured from pCO, this field defines the third probe on the EVD ⁴ , the probe is read only and sent to the pCO. The read options and the probes available depend on the control settings: - NTC - NTCh - Pt1000 - Pressure"
Aux. probe limits Max	I	44	9,3	9,3	9,3	ratiometric end scale pressure S2	Value corresponding to 100% of the pressure read by the ratiometric probe connected to channel S2
Aux. probe limits Min	I	43	-1	-1	-1	ratiometric zero pressure S2	Value corresponding to 0% of the pressure read by the ratiometric probe connected to channel S2
Battery presence	I	63				enable valve not closed error	used if EVD ⁴ is installed with a backup battery, enables the EEV not closed error (see the corresponding description of the parameter), from pCO
Blocked valve check	I	51	0	0	0	time after which the valve is considered as being blocked	If SH is high and the valve is open or if SH is low and the valve is closed, the valve may be considered blocked. This parameter defines the delay before performing, respectively, a forced closing or a forced opening.
Calibr. S4 gain mA	I	111	0	0	0	current gain on channel S4	This is the correction to the end scale in the calibration of channel S4, used to receive a 4-20 mA signal when the driver is operating as a positioner
Calibr. S4 gain Volt	I	113	0	0	0	voltage gain on channel S4	This is the correction to the end scale in the calibration of channel S4, used to receive a 0-10 Volt signal when the driver is operating as a positioner
Calibr. S4 offs mA	I	112	0	0	0	current offset on channel S4	This is the correction to the deviation from zero in the calibration of channel S4, used to receive a 4-20 mA signal when the driver is operating as a positioner
Calibr. S4 offs Volt	I	114	0	0	0	voltage offset on channel S4	This is the correction to the deviation from zero in the calibration of channel S4, used to receive a 0-10 Volt signal when the driver is operating as a positioner

	Capacity control						EVD ⁴ macroblock parameter that defines the type of compressor control	"According to the type of compressor control selected, the macroblock calculates the proportional factor, which will be entered indiscriminately for the parameters CH-Proportional gain, HP-Proportional gain and DF-Proportional gain. Multiple choice: - "none or stages" if the compressor is without capacity control or with step control - "continuous slow" for screw compressors with slider control - "continuous fast" for compressors with inverter control"
■	CH-Circuit/EEV Ratio	I	20				percentage of the maximum capacity managed by the valve	This is the ratio between the maximum cooling capacity delivered by the valve and the maximum in the circuit, in cooling or CH mode, if managed. Used to pre-position the valve when starting and/or changing capacity (if possible), sent by the pCO or μC^2 controller (e.g. if the ratio is 40% and if the capacity of the system changes to 1/2 of the current level, the pCO or μC^2 tells the driver to preposition the valve at half of 40%, that is, equal to 20% of the total capacity of the valve, minus the Dynamic proportional gain factor), once the driver has completed pre-positioning, independent SH control will commence
■	CH-Integral time	A	28	30	30	80	integral time for superheat control	This is the time of the PID integration action, increasing the value the SH reaches the set point more slowly but avoids excessive swings. This depends on the type of evaporator and the inertia of the circuit. If HP and DF modes are also available, this refers to control in CH mode
□	CH-Low Superheat	A	43	2,5	2,5	6	low superheat value	This is the minimum SH value below which the system activates the Alarm Low Superheat after the Alarms delay Low SH. This is used to avoid an excessively low pressure difference between the condenser and evaporator circuits, which may cause liquid at the compressor intake. If HP and DF modes are also available, this refers to control in CH mode
■	CH-Proportional gain	A	25	3	2,5	7	PID proportional factor	This is the PID proportional factor, increasing the value increases the reactivity of the valve and therefore of SH control, however for high values control may become unstable. This depends on the ratio between circuit capacity and valve capacity and on the maximum number of valve control steps. If HP and DF modes are also available, this refers to control in CH mode
■	CH-Superheat set	A	22	6	6	10	superheat set point	Superheat set point. If HP and DF modes are also available, this refers to control in CH mode. Do not set excessively low values (less than 5°C) or too near the low superheat limit (at least 3°C difference).
	Closing extra steps	I	63				enable extra steps in closing	Enables the extra steps function when closing: when the driver closes the valve but the SH value measured is not coherent (too low), the driver realises that the valve is not completely closed and forces some extra closing steps at preset intervals, until the SH reaches coherent values. Maximum steps/128 are completed every second. Used by pCO.
	Closing steps	I	24	500	500	500	steps completed in total closing	Number of steps that the driver uses to totally close the valve (not during control)
	Compressor or unit						macroblock parameter that defines the integral time	"Identifies the type of unit/compressor that the expansion valve is used on. This selection optimises the PID control parameters and the auxiliary Driver protectors, considering the control characteristics of the various types of system. 1 Reciprocating 2 Screw 3 Scroll 4 Flooded cabinet 5 Cabinet"
	Cond. probe press.	A	12	0	0	0	condensing pressure value measured	Condensing pressure value measured, from μC^2 or pCO
	Cond. probe sat. temp.	A	9	0	0	0	saturated gas temperature in the condenser	Saturated gas temperature value calculated in the condenser, from μC^2 or pCO
	STEPCOUNTH	I	95	0	0	0	step counter high word	Step counter in hexadecimal format, high part
	STEPCOUNTL	I	94	0	0	0	step counter low word	Step counter in hexadecimal format, low part
	Cool						macroblock parameter that defines the integral time	"Identifies the type of exchanger used as the evaporator in cooling mode: 1 Plates 2 Shell&tube 3 Fast finned 4 Slow finned This selection optimises the PID control parameters and the auxiliary Driver protectors, considering the control characteristics of the various types of system."
□	Derivative time	A	31	1	1	1	PID derivative time	This is the time of the PID derivative action, increasing the value decreases swings but bring fluctuations vibrations around the SH set point.
	DF-Circuit/EEV Ratio	I	20				percentage of the maximum capacity managed by the valve in DF mode, from pCO	This is the ratio between the maximum cooling capacity delivered by the valve and the maximum in the circuit, in DF mode. Used to pre-position the valve when starting and changing capacity, sent by the pCO or μC^2 controller (e.g. if the capacity of the system changes to 50%, the pCO or μC^2 tells the driver to preposition the valve at 50% of its total travel, minus the Dynamic proportional gain factor, then the driver will commence independent SH control), from pCO or μC^2 .
	DF-Integral time	A	30	30	30	30	integral time for superheat control in DF mode	This is the time of the PID integration action in the operation in DF mode, increasing the value the SH reaches the set point more slowly but avoids excessive swings. This depends on the type of evaporator and the inertia of the circuit.
	DF-Low Superheat	A	45	4	4	4	low superheat value in DF mode	This is the minimum SH value below which the system activates the Alarm Low Superheat after the Alarms delay Low SH in the operation in DF mode. This is used to avoid an excessively low pressure difference between the condenser and evaporator circuits, which may cause liquid at the compressor intake.
	DF-Proportional gain	A	27	4	4	4	PID proportional factor in DF mode	This is the PID proportional factor per operation in DF mode, increasing the value increases the reactivity of the valve and therefore of SH control, however for high values control may become unstable. This depends on the ratio between circuit capacity and valve capacity and on the maximum number of valve control steps.
	DF-Superheat set	A	24	10	10	10	superheat set point in DF mode	Superheat set point in operation DF
	Digital input 1	D	17	0	0	0	status of digital input 1	Checks the status of digital input 1 (enabled or disabled)
	Digital input 2	D	18	0	0	0	status of digital input 2	Checks the status of digital input 2 (enabled or disabled)
	DOU2	D	21	0	0	0	relay output control	Variable that checks and/or signals the opening or closing of the relay, 0 = open, 1 = closed
	Driver X high superheat						driver X with high superheat	EVD200 alarm, driver X with high superheat, checks the sensors on driver X
	DriverX mode						operating mode of the X-th driver	Operating mode of the X-th driver (CH, HP, DF), from pCO
	Duty cycle	I	29	30	30	30	motor duty cycle	Duration of the control signal sent by the driver to the valve in one second, as a percentage (100% = continuous signal)

Dynamic proportional gain	I	71	0,6	0,6	0,6	attenuation coefficient with change in capacity	Parameter active for each change in capacity of the circuit: when the driver pre-positions the valve (see CH-Circuit/EEV Ratio, HP-Circuit/EEV Ratio, and DF-Circuit/EEV Ratio); the difference between the initial and the final position is multiplied by value of this parameter, between 0 and 1, and the effect of the change in capacity on the SH is attenuated.
EEV mode man.	D	68	0	0	0	enable/disable manual valve positioning	Enables/disables manual valve positioning, eliminating the activation of any control or alarm
EEV not closed	D	47	0	0	0	active due to failed valve closing	If the EVD400 is installed with a backup battery, in the event of mains power failures or no communication with the controller for more than 30 sec, the valve is closed. If during this procedure EVD400 cannot control all the steps to close the valve due to lack of backup power (flat battery), when restarting the EEV not closed error is displayed, with the consequent Go ahead request
EEV opening	A	17	0	0	0	valve opening as a %	Controlled opening of the valve as a %
EEV position	I	15	0	0	0	calculated valve opening position	Calculated opening of the valve, in steps
En. positioner	I	63				enable/disable manual positioner function	Enables/disables the manual positioner function, from pCO
Enable reset to default	I	1	0	0	0	enable restore default parameters	If set to 14797, allows the user to reset all the parameters to the default values by enabling the Reset to default variable
Ev. probe press.	A	14	0	0	0	evaporation pressure value measured	Value measured by the evaporation pressure probe
Ev. probe sat. temp.	A	16	0	0	0	saturated gas temperature value calculated in the evaporator	Saturated gas temperature value calculated in the evaporator, taken from the evaporation pressure on the Mollier chart
Evaporator type cool						type of evaporator in CH mode	"Identifies the type of exchanger used as the evaporator in cooling mode: 1 • Plates 2 • Shell&tube 3 • Fast finned 4 • Slow finned This section configures the integral time in the PID control parameters."
Evaporator type heat						type of evaporator in HP mode	"Identifies the type of exchanger used as the evaporator in heating mode: 1 • Plates 2 • Shell&tube 3 • Fast finned 4 • Slow finned This section configures the integral time in the PID control parameters."
EVD probes type	I	69	0	0	0	type of sensors used	"Number that indicates the combination of sensors used to calculate the superheat value; the default value 51 corresponds to a ratiometric probe connected to S1 and a 103 AT NTC sensor temperature to S3. For other connections, set the value of the parameter according to the following formula: EVD probes type = CFGS1 + 5 * CFGS2 + 25 * CFGS3 where: CFGS1 (probe on channel S1) = 0, 1 or 2 CFGS2 (probe on channel S2) = 0, 1, 3 or 4 CFGS3 (probe on channel S3) = 0, 1 or 2 and: 0 = no measurement 1 = ratiometric pressure 2 = NTC 103AT (10000 ohm at 25 °C) 3 = NTC IHS (50000 ohm at 25 °C) 4 = Pt1000"
EVD type						model of EVD used	Model of EVD used, from pCO
EVD version H.W	I	100	0	0	0	driver hardware version	Driver hardware version
EVD version S.W	I	100	0	0	0	software version installed on the driver	Software version installed on the driver
Force	D	8	0	0	0	send a FORCE command to the EVD	Transmission of all the parameters or variables
Functional test	D	2	0	0	0	functional test	The functional test is a status of the driver that is used to check the operation of the device, and in particular to calibrate a number of variables
Go ahead	D	35	0	0	0	enable restart following error	"When the driver signals one of the following errors: - Probe error alarm - EEPROM error alarm - EEV not closed authorisation is requested continue after the user has checked the existence and the seriousness of the problem."
Heat						type of evaporator in HP mode	"Identifies the type of exchanger used as the evaporator in heating mode: 1 • Plates 2 • Shell&tube 3 • Fast finned 4 • Slow finned This section configures the integral time in the PID control parameters."
Hi TCond. int. time	A	36	0	0	0	integral time for high condensing temperature control (HiTCond)	Integral time for high condensing temperature control, see Hi TCond. protection
Hi TCond. protection	A	40	80	80	80	maximum condensing temperature	Maximum condensing temperature; once exceeded, the driver starts controlling the valve position based on this set point and considering the Hi TCond. int. Time parameter
High superheat alarm threshold	A	37	200	200	200	maximum superheat temperature	Maximum superheat temperature. If HP and DF modes are also available, this refers to control in CH mode
High Tc status	D	53	0	0	0	active when in high condensing temperature control status	Active when in high condensing temperature control mode, see Hi TCond. protection
HP-Circuit/EEV Ratio	I	20				percentage of the maximum capacity managed by the valve in HP mode, from pCO	This is the ratio between the maximum cooling capacity delivered by the valve and the maximum in the circuit, in HP mode. Used to pre-position the valve when starting and changing capacity, sent by the pCO or μC^2 controller (e.g. if the capacity of the system changes to 50%, the pCO or μC^2 tells the driver to preposition the valve at 50% of its total travel, minus the Dynamic proportional gain factor, then the driver will commence independent SH control), from pCO or μC^2 .
HP-Integral time	A	29	35	35	200	integral time for superheat control in HP mode	This is the time of the PID integration action for operation in HP mode, increasing the value the SH reaches the set point more slowly but avoids excessive swings. This depends on the type of evaporator and the inertia of the circuit.
HP-Low Superheat	A	44	3	3	6	low superheat value in HP mode	This is the minimum SH value below which the system activates the Alarm Low Superheat after the Alarms delay Low SH in the operation in HP mode. This is used to avoid an excessively low pressure difference between the condenser and evaporator circuits, which may cause liquid at the compressor intake.

	HP-Proportional gain	A	26	3	3	3	PID proportional factor in HP mode	This is the PID proportional factor for operation in HP mode, increasing the value increases the reactivity of the valve and therefore of SH control, however for high values control may become unstable. This depends on the ratio between circuit capacity and valve capacity and on the maximum number of valve control steps.
	HP-Superheat set	A	23	7	7	10	superheat set point in HP mode	Superheat set point in HP mode
	KEY1	I	1	0	0	0	special functions	"If set to 14797, allows the user to reset all the parameters to the default values, by enabling the Reset to default variable. If set to 19157, allows the user to remain in functional test mode, enabling the Functional test variable within 30 s from when the driver is switched on (see the paragraph "Application as positioner" in the EVD400 Manual)"
	KEY11	I	11	0	0	0	enable write advanced valve parameters if set to 24717 (Service only)	Enable write advanced valve parameters if set to 24717 (Service only)
	KEY12	I	14	0	0	0	special functions	If set to 12233 within 250 s from when the driver is switched on, disables the termination of the functional test by timeout (see the paragraph "Application as positioner" in the EVD400 Manual)
□	LOP Cool Mode	A	50	-5	-5	-45	temperature at minimum operating pressure (MOP) in CH mode	Temperature at the minimum operating pressure allowed at the evaporator outlet, in CH mode. When the temperature is less than the set threshold, the system goes into LOP status, activating the LOP status digital variable and LOP control: the driver stops SH control and starts controlling the valve position so as to reach the LOP set point, considering the LOP integral time parameter. The driver resumes SH control when the temperature returns above the set threshold.
	LOP Defr. Mode	A	52	-30	-30	-30	temperature at minimum operating pressure (LOP) in DF mode	Temperature at the minimum operating pressure allowed at the evaporator outlet, in DF mode. When the temperature is less than the set threshold, the system goes into LOP status, activating the LOP status digital variable and LOP control: the driver stops SH control and starts controlling the valve position so as to reach the LOP set point, considering the LOP integral time parameter. The driver resumes SH control when the temperature returns above the set threshold.
	LOP Heat Mode	A	51	-25	-20	-45	temperature at minimum operating pressure (LOP) in HP mode	Temperature at the minimum operating pressure allowed at the evaporator outlet, in HP mode. When the temperature is less than the set threshold, the system goes into LOP status, activating the LOP status digital variable and LOP control: the driver stops SH control and starts controlling the valve position so as to reach the LOP set point, considering the LOP integral time parameter. The driver resumes SH control when the temperature returns above the set threshold.
	LOP integral time	A	34	1,5	1,5	0	integral time for low evaporation pressure control (LOP)	Integral time for low evaporation pressure (LOP) control, see LOP cool mode
	LOP status	D	50	0	0	0	active when in minimum evaporation pressure control status	Active when in LOP control status, see LOP cool mode
	Low SH int. time	A	33	1	1	15	integral time for low superheat control	Integral time for low superheat control, see CH-Low Superheat
	Low SH status	D	52	0	0	0	active when in low superheat control status	Active when the superheat measured is lower than CH-Low Superheat (or similar in HP or DF mode)
	Maximum steps	I	23	480	480	480	maximum control steps	Position beyond which the valve is considered completely open
	Minimum steps	I	22	30	30	30	minimum control steps	Position below which the valve is considered closed. This parameter is only used during repositioning (see CH-Circuit/EV Ratio)
	MODE	I	16	0	0	0	READ ONLY, received from µC	"Received from µC, describes the type of cycle that the main controller is managing: 0 = cooling (CH) 1 = heating (HP) 2 = defrost (DF) 3 = pump-down"
□	MOP Cool Mode	A	53	12	80	80	temperature at maximum operating pressure (MOP) in CH mode	Temperature at the maximum operating pressure allowed at the evaporator outlet, in CH mode. When the temperature is greater than the set threshold, the system enters MOP status, activating the MOP status digital variable and MOP control: the driver stops SH control and starts controlling the valve position so as to reach the MOP set point, considering the MOP integral time parameter. The driver resumes SH control when the temperature returns below the set threshold.
	MOP Defr. Mode	A	55	30	30	30	temperature at maximum operating pressure (MOP) in DF mode	Temperature at the maximum operating pressure allowed at the evaporator outlet, in DF mode. When the temperature is greater than the set threshold, the system enters MOP status, activating the MOP status digital variable and MOP control: the driver stops SH control and starts controlling the valve position so as to reach the MOP set point, considering the MOP integral time parameter. The driver resumes SH control when the temperature returns below the set threshold.
	MOP Heat Mode	A	54	12	12	80	temperature at maximum operating pressure (MOP) in HP mode	Temperature at the maximum operating pressure allowed at the evaporator outlet, in HP mode. When the temperature is greater than the set threshold, the system enters MOP status, activating the MOP status digital variable and MOP control: the driver stops SH control and starts controlling the valve position so as to reach the MOP set point, considering the MOP integral time parameter. The driver resumes SH control when the temperature returns below the set threshold.
	MOP integral time	A	35	2,5	2,5	0	integral time for high evaporation pressure control (MOP)	Integral time for high evaporation pressure (MOP) control, see MOP cool mode
	MOP startup delay	I	49	60	60	60	MOP delay time when starting control	When the system is started, the evaporation pressure is high and may exceed the set MOP threshold. The duration of the MOP delay time can be set when starting the controller
	MOP status	D	49	0	0	0	active when in maximum evaporation pressure control status	Active when in MOP control status, see MOP cool mode
	Net address	I	21	2	30	250	network address	Network address
	NUMRESTART	I	91	0	0	0	EVD ⁴ start counter (power supply).	EVD ⁴ start counter (power supply) and reset.
	NUMVALVECLOSE	I	93	0	0	0	valve closing counter.	Valve closing counter.
	NUMVALVEOPEN	I	92	0	0	0	EVD ⁴ start counter with valve error.	EVD ⁴ start counter with valve error.
	Off SH cl	A	46	0	0	10	superheat offset with modulating temperature in CH mode	Superheat offset with modulating temperature in CH mode
	Open relay low SH	D	60	1	0	1	enable/disable relay opening following low superheat	Enables/disables the opening of the relay when the driver is in Low SH status
	Open relay MOP	D	61	0	0	0	enable/disable relay opening following MOP	Enables/disables the opening of the relay when the driver is in MOP status
	Opening extra steps	I	63				enable extra steps in opening	When the valve has reached the 100% of the control steps in opening, as set by the parameters for each valve or the Maximum steps parameter, and the procedure requires further opening, the driver attempts to further open the valve by controlling [Maximum steps/128] steps every second, if this parameter is enabled. In addition, allows any steps lost during control, when opening, to be recovered. Used by pCO
	Phase current	I	27	450	450	450	peak current per phase	Peak current that the driver supplies to each valve control phase

	Power request						cooling capacity	Reading of the cooling capacity, from pCO
	Probes offset S1	A	1	0	0	0	correction of S1	Correction of the value measured by sensor S1
	Probes offset S2	A	2	0	0	0	correction of S2	Correction of the value measured by sensor S2
	Probes offset S3	A	3	0	0	0	correction of the lower limit of S3	Correction of the value measured by sensor S3
	Refrigerant	I	50	4	3	2	number indicating the type of refrigerant used	"Type of refrigerant (consult the electronic expansion valve technical documentation to check the complete valve-driver system compatibility with the chosen refrigerant): 1 = R22 2 = R134a 3 = R404a 4 = R407c 5 = R410a 6 = R507a 7 = R290 8 = R600 9 = R600a 10 = R717 11 = R744 12 = R728 13 = R1270"
	Regulation	I	200				READ ONLY, received from μC^2	READ ONLY, received from μC^2
	Regulation type	I	17	0	0	0	type of control	"Type of control, if EEV man. mode is not enabled: 0 = standard PID with protectors 1 = simple PID without protectors 2 = positioner on S4 In positioner mode, the activation of any control or alarm is disabled: the driver positions the valve between 0 and the Maximum steps proportionally to a signal on input S4 (see the instruction sheet), either 0-10 Volt or 4-20 mA"
	Re-install AUTOSETUP values						confirm enable restore default parameter values	Confirms the reset of default parameter values, based on the information entered for the System Set group of parameters from the pCO
	Relay stdby	D	58	0	0	0	relay status in standby, in stand-alone mode	Relay status in standby (unit powered but capacity demand equal to 0) when the driver operates in stand-alone mode: normally the relay is open, if 1 the relay is closed
	Requested steps	I	62	0	0	0	required motor position in manual control	Required position of the motor in manual control
	Reset to default	D	1	0	0	0	restore the values of the parameters to the default, tLAN version	Restores the parameters to the internal default values if Enable reset to default or KEY1 are equal to 14797, tLAN version
■	S1 probe limits Max	I	42	9,3	9,3	9,3	end scale for pressure sensor on input S1	Pressure value corresponding to the maximum of ratiometric output S1 (4.5 V).
■	S1 probe limits Min	I	41	-1	-1	-1	'zero' scale for pressure sensor on input S1	Pressure value corresponding to the minimum of ratiometric output S1 (0.5 V).
	S2-Pt1000 calib.	I	68	0	0	0	calibration index for PT1000 sensor	Calibration value engraved on the metallic body of the probe, minus 1000.0.
	S4 probe type	I	36	0	0	0	type of probe on channel S4	"Number that indicates the type of sensor connected to input S4: 0 = no measurement 5 = 4-20 mA 6 = 0-10 V"
	S4 signal	A	7	0	0	0	signal on input S4	Reading of the input signal on S4
	SHeat dead zone	A	32	0	0	0	dead zone for PID control	Value that defines an interval around the SH set point: if the SH measured is within this interval, the driver stops control and the valve will not perform any movements; control resumes when the superheat value is outside of the dead zone.
■	Stand alone	D	67	0	0	1	enable StandAlone	Enables the StandAlone function from μC^2 or supervisor, the driver will operate in this mode if digital input ID1 is enabled
	Stand alone	I	63				enable StandAlone	Enables StandAlone from pCO, the driver will operate in this mode if digital input ID1 is enabled
	Standby steps	I	25	5	5	5	number of valve back steps	Number of the steps for reopening the valve after complete closing, to release the end spring
	Steprate	I	26	100	100	100	motor speed	Speed of the stepper motor, in steps/s
	Still current	I	28	120	120	120	current with the motor off	Current running through the motor when stationary
	Suction temp.	A	13	0	0	0	value measured by the suction temperature sensor	Value measured by the suction temperature sensor
	Superheat	A	15	0	0	0	superheat value measured	Value of the superheat calculated on the Mollier chart using the suction temperature and evaporation pressure values
	T diff cl	A	48	3	3	3	temperature differential with modulating thermostat in CH mode	Differential temperature with modulating thermostat in CH, equal to the proportional band
	TX not filtered	D	54	0	0	1	enable complete TX on tLAN/485	Set to 0, limits transmission on the main serial port only to the variables required for the operation with the microchiller.
	VAC	D	19	0	0	0	alternating current power supply status	Read-only, if 0 the power supply is present, if 1 it is not present.
□	Valve alarm	D	70	1	1	1	enable/disable valve alarm	Enables/disables the valve alarm (valve not closed at shutdown alarm), see EEV not closed

■	Valve type	I	30	0	0	0	number that defines the type of electronic valve used	"Number that defines the type of electronic valve used and selects the motor operating parameters from a table. The following valves are supported: 0 = CAREL E2V 1 = Sporlan SEI 0.5-20 2 = Sporlan SEI 30 3 = Sporlan SEH 50-250 4 = Alco EX5-EX6 5 = Alco EX7 6 = Alco EX8 330 step/s 7 = Alco EX8 500 step/s 8 = Danfoss ETS-25/50 9 = Danfoss ETS-100 10 = CAREL E2V*P 11 = Danfoss ETS-250/400 >12 and <99 = direct setting of the parameters (custom valve)"
	XPA	D	65	0	0	1	enable extra steps in opening	When the valve has reached the 100% of the control steps in opening, as set by the parameters for each valve or the Maximum steps parameter, and the procedure requires further opening, the driver attempts to further open the valve by controlling [Maximum steps/128] steps every second, if this parameter is enabled. The procedure is stopped if the condition persists for [Maximum steps/3] steps. In addition, allows any steps lost during control, when opening, to be recovered.
	XPC	D	66	0	0	1	enable extra steps in closing	Enable the extra steps function when closing: when the driver closes the valve but the SH value measured is not coherent (too low), the driver realises that the valve is not completely closed and attempts to close it by performing [Maximum steps/128] steps every second, until the SH reaches coherent values. The procedure is stopped if the condition persists for [Maximum steps/3] steps. In addition, allows any steps lost during control, when closing, to be recovered.
	Note							"SH = superheat CH = chiller mode HP = heat pump mode DF = defrost mode MOP = maximum operating pressure LOP = lowest operating pressure HiT = high temperature EEV = electronic expansion valve GREEN or FALSE or OFF or 0 or DISABLED have the same meaning, in relation to the meaning of the reference parameter RED or TRUE or ON or 1 or ENABLED have the same meaning, in relation to the meaning of the reference parameter"

Note: SH= superheat
CH= chiller mode;
HP= heat pump mode;
DF= defrost;
MOP= Maximum Operating Pressure;
LOP= Lowest Operating Pressure;
HiT= High Temperature);
EEV= Electronic Expansion Valve;

GREEN or FALSE or OFF or 0 or DISABLED have the same meaning, in relation to the meaning of the reference parameter;

RED or TRUE or ON or 1 or ENABLED have the same meaning, in relation to the meaning of the reference parameter".

 **WARNING!**
All the parameters corresponding to integral and derivative times, if set to 0, disable the corresponding function.

		Raziom.	NTC 103AT	NTC IHS	Pt1000	4...20 mA	0...10 V
limits	min	0,3	+99 °C	+153 °C	-60 °C	3 mA	0 V
	MAX	4,7	-57 °C	-25 °C	+161 °C	22 mA	11 V
limits if applied to inputs other than those recommended (see Chapter 4)	min		204,7 °C	69,9 °C	+2220 °C		
	MAX		-13,6 °C	-59,2 °C	+6650 °C		

APPENDIX III. PARAMETER SETTINGS

The following values are recommended as a reference and starting point for the configuration of the EVD400 and the PID control.

The users can then check whether or not these values are correct based on their own acceptability criteria, and then change them if necessary.

N.B.: the pressure probe is connected to S1.

ENGLISH

Primary

Application	Refrigerant*	Valve type	S1 probe limits Min [bar]	S1 probe limits Max [bar]	"CH Circuit EEV ratio"	CH Superheat set [°C]	CH Proportional gain	CH Integral time [sec]	"Derivative time [sec]"	
Chiller NB consider double CH Proportional Gain in case of Inverter or Stepless Compressor	1 = R22; 2 = R134a; 3 = R404a; 4 = R407c; 5 = R410a; 6 = R507a; 7 = R290; 8 = R600; 9 = R600a; 10 = R717; 11 = R744; 12 = R728; 13 = R1270	0 = CAREL E2V 1 = Sporlan SER 0.5-20 2 = Sporlan SEI 30 3 = Sporlan SEH 50-250 4 = Alco EX5-EX6 5 = Alco EX7 6 = Alco EX8 330 step/s 7 = Alco EX8 500 step/s 8 = Danfoss ETS-25/50 9 = Danfoss ETS-100 10 = CAREL E2V*P 11 = Danfoss ETS-250/400 > 12 Custom	See pressure probe technical leaflet	See pressure probe technical leaflet	70	6	CAREL E2V = 4 Alco Ex5/6 = 7 Sporlan 0.5/20, Alco Ex7 = 10 Sporlan 30, Alco Ex8, Danfoss ETS = 25 Sporlan 50/250 = 45	35		
Chiller low temperature							CAREL E2V = 3 Alco Ex5/6 = 6 Sporlan 0.5/20, Alco Ex7 = 12 Sporlan 30, Alco Ex8, Danfoss ETS = 18 Sporlan 50/250 = 35	30		
Cold room packaged							CAREL E2V = 3 Alco Ex5/6 = 6 Sporlan 0.5/20, Alco Ex7 = 8 Sporlan 30, Alco Ex8, Danfoss ETS = 18 Sporlan 50/250 = 35	50		
Cold room centralized							CAREL E2V = 7 Alco Ex5/6 = 10 Sporlan 0.5/20, Alco Ex7 = 10 Sporlan 30, Alco Ex8, Danfoss ETS = 25 Sporlan 50/250 = 45	70		1
Air conditioner							CAREL E2V = 3 Alco Ex5/6 = 6 Sporlan 0.5/20, Alco Ex7 = 8 Sporlan 30, Alco Ex8, Danfoss ETS = 18 Sporlan 50/250 = 35	35		
Display cabinet plug-in							CAREL E2V = 5 Alco Ex5/6 = 8 Sporlan 0.5/20, Alco Ex7 = 10 Sporlan 30, Alco Ex8, Danfoss ETS = 25 Sporlan 50/250 = 45	60		
Display cabinet centralized	CAREL E2V = 7 Alco Ex5/6 = 10 Sporlan 0.5/20, Alco Ex7 = 10 Sporlan 30, Alco Ex8, Danfoss ETS = 25 Sporlan 50/250 = 45	100								

* Consult the electronic expansion valve technical documentation to check the complete valve-driver system compatibility with the chosen refrigerant

Secondary:

Ch low Superheat: Recommended value 2°C with superheat set point greater than 4°C.

If the superheat set point is lower, the low superheat threshold must also be reduced, guaranteeing a difference of at least 2 °C between the two.

Low SH int. time: Recommended value 1.0 seconds with a threshold of 2°C. If the threshold is lower, the time must also be reduced to 0.5 seconds. N.B.: A value of 0 (zero) seconds completely disables the protection.

LOP cool mode: Recommended value from 5 °C to 10 °C below the typical minimum saturated evaporation temperature of the installation. Example: for chillers with a rated evaporation temperature of 3 °C and a minimum tolerated evaporation temperature of -1 °C, set the LOP Limit to -6 °C

LOP integral time: Recommended value 2 seconds, to be increased to approx. 10 seconds if the action is too intense (excessive opening of the valve as a response to low pressure) and reduced to 1 second if the action is insufficient (excessively low evaporation temperature). N.B.: A value of 0 (zero) seconds completely disables the protection.

MOP startup delay: Recommended value 60 seconds, however the changeability of the starting dynamics of different units means the time needs to be optimised: in the set time the evaporation pressure must fall below the value set for "MOP cool mode" to effectively activate the MOP.

MOP cool mode: The value set depends on the refrigerating unit and its design, and is indeed a design value of the unit: no recommendations can be made.

MOP integral time: Recommended value 2 seconds, to be increased to approx. 10 seconds if the action is too intense (excessive closing of the valve as a response to high pressure) and reduced to 1 second if the action is insufficient (excessively high evaporation temperature).

N.B.: A value of 0 (zero) seconds completely disables the protection.

IV.I Symbols used

In this introduction to PID control, reference is made to the following block diagram, which is a simplified representation of an cycle control individual:

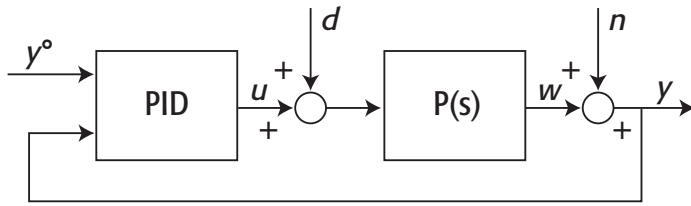
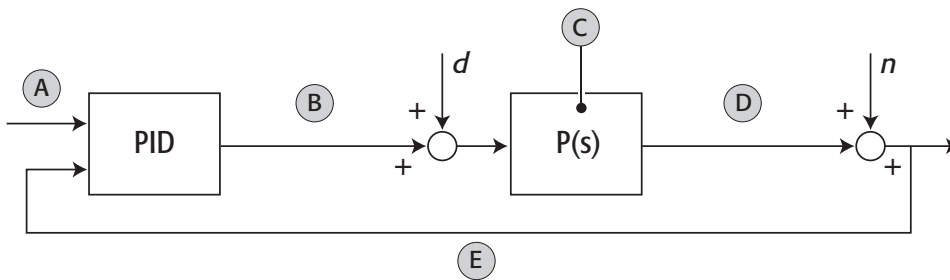

Fig. 1

With the following symbols:

symbol	meaning
$y^o(t)$	Reference signal or set point
$w(t)$	Controlled or process variable
$y(t)$	Value of the controlled or process variable
$e(t)$	Error, defined as $e(t)=y^o(t)-y(t)$
$u(t)$	Control variable
$d(t)$	Load disturbance
$n(t)$	Measurement noise
PID	PID control
$P(s)$	Transfer function describing the process being controlled

If the PID control manages the superheat value by positioning the electronic expansion valve, which we have called the SH PID, then:



Key

A	$y^o(t)$ = SH set point
B	$u(t)$ = valve position
C	lamination process
D	$w(t)$ = real SH
E	$y(t)$ = measured SH

Fig. 2

IV.II Pid control law

PID control in its simplest form is defined by the following law

$$u(t) = K_p e(t) + K_i \int e(t) dt + K_d \frac{de(t)}{dt} \quad \text{oppure} \quad u(t) = K \left(e(t) + \frac{1}{T_i} \int e(t) dt + T_d \frac{de(t)}{dt} \right)$$

This means that the control is calculated as the sum of three contributions:

P or proportional action $Ke(t)$ (k = proportional gain)

I or integral action $\frac{K}{T_i} \int e(t) dt$ (T_i = integral time)

D or derivative action $\frac{K}{T_d} \int e(t) dt$ (T_d = derivative time)

hence the definition 'PID control'.

IV.III Proportional action

EFFECT OF K

Increasing the value of the proportional gain, increases the reactivity of the valve, to the limit where this may cause instability and not reach the set point with precision. This depends on the ratio between the circuit capacity and the valve capacity, and on the maximum number of valve control steps.

The proportional action guarantees control over the process variable that is proportional to the system error at the instant t . The controller performs a corrective action on the control variable, at the instant t , that is equal to $u(t)=K \cdot e(t)=K \cdot (y(t)-y_0(t))$.

The proportional action follows the logic whereby the greater the error, instant by instant, the more

intense the action on the process so as to bring the controlled variable to the desired value. It is important to note that this has a value other than zero only if the error is not zero: therefore, in steady operation this is ideally zero. In reality, in steady operation (stable at the set point) it still follows the fluctuations in the controlled variable due, for example, to measurement noise, and it can be shown that alone it may not reach the set point, maintaining a certain deviation from the latter. The proportional action makes its contribution in the initial transient periods; then, when the error decreases, it loses effectiveness. To determine the proportional gain K, consider the relationship between the input and output of a controller to be purely proportional, as shown in the figure, for two values different of the gain, where the input and the output are represented as percentages of their field of variation:

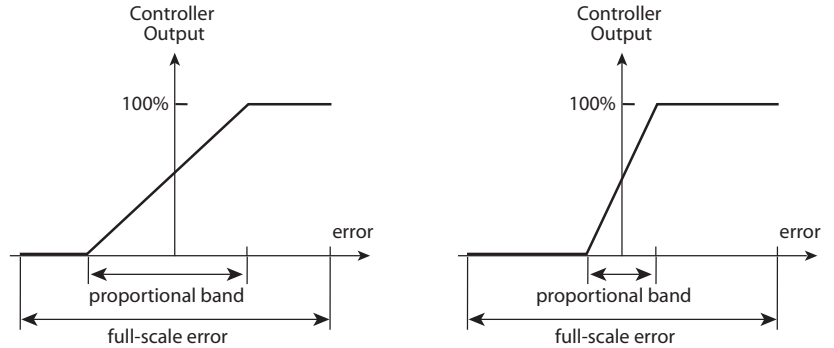

Fig. 3

Defining the variation in the input (as a percentage of its field of variation) as the proportional band BP that causes a 100% variation in the output, if the input and output signals have the same physical type and vary within the same field of values (for example 4 to 20 mA), the gain K is: $K_p = \frac{100}{BP\%}$

In the first diagram in Fig. 3, Bp=50%, hence Kp=2, while in the second BP=10% and thus Kp=10. The proportional action of the PID controllers is set by the operator as the proportional band changes.

EXAMPLE: Consider the case of a controller with a 4 to 20 mA input and 0 to 10 V output: when BP=10%, a 1.6 mA variation in the input produces a variation from 0 to 10 V at the output, that is, the total gain is 10/1.6=6.25 V/mA.

In the case of the SH PID:

valve pos. (SH set point – SH measured(t))

$$K = \left(\frac{\text{step max reg}}{100} \cdot \frac{Q \text{ circuit}}{Q \text{ valve}} \right) \pm 20\%$$

where:

- step max reg = maximum electronic expansion valve control steps
- Q circuit = capacity in kW of the refrigerant circuit in steady operation
- Q valve = capacity in kW of the electronic expansion valve in the same operating conditions as Q circuit

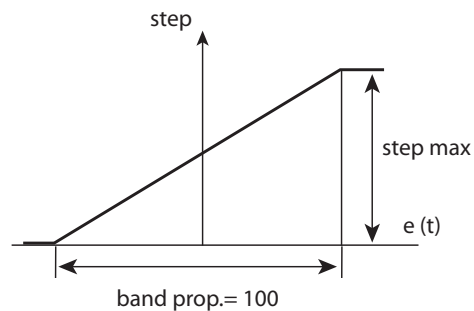

Fig. 4

IV.IV Integral action

EFFECT OF Ti

Increasing the value of the integral time Ti, the valve reaches the set point more slowly but avoids excessive swings. This depends on the type of evaporator and the inertia of the circuit.

The integral action is used to guarantee that the error is null in steady state. Indeed, the integral action is not zero if there is no error; quite the opposite, if for example the error remains stable, it continues to increase linearly, following the principle whereby “until the controlled variable decides to move in the direction I want, I will continue to apply an increasingly intense action”. Consequently, the integral action not only considers the current value, at the instant of the error, but also the past values.

As a result, if steady state is reached, that is, the error is null, the only contribution to control will be the EVD⁴ +030220227 - rel. 2.1 - 12.06.2008

integral action. It is almost always the integral action that dominates the way in which the system reaches steady operation.

The integral action by definition does not make "jumps" and therefore is the slowest to react. Indeed, it has almost no effect during the initial transient periods: these periods are dominated by the other two actions. To define the integral time, the PI action is considered: $u(t) = K_p e(t) + K_i \int e(t) dt$

and the response of the two terms to the step change (i.e. +10%), as shown in the figure:

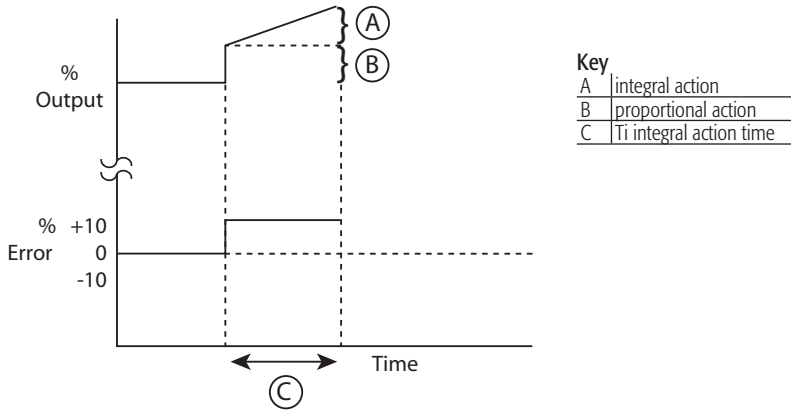

Fig. 5

Integral time (reset time, integral constant or doubling time) is defined as the time required for the response of the I part to be equal to that of the P part. That is, the total response to the step change is double the value of the proportional part alone.

In the case of the SH PID, the integral time depends on the type of evaporator (plate, tube bundle, ...) and the thermal inertia of the circuit; the more 'reactive' the system, the lower the contribution of the integral action must be.

IV.V Derivative action

EFFECT OF Td

Increasing the value of the derivative time T_d decreases swings, however there may be fluctuations around the set point.

The derivative action makes the control depend on the "future" of the error, that is, on the direction it is moving in and the speed it varies. In fact, the derivative action calculates an estimate for the error after t seconds based on the trend of the curve at the instant t (see the following figure) and therefore ensures that control will depend on a prediction of the error T_d at a future instant of time.

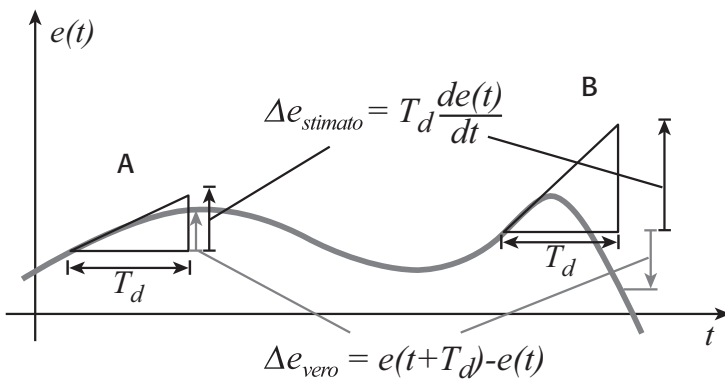

Fig. 6

The derivative action "tries to understand where the error is going and how fast it is moving" and reacts as a consequence; the parameter T_d determines how far into the future the prediction is made.

The derivative action is the fastest to react (including to measurement noise, unfortunately) and is only helpful if the prediction is good, that is, if T_d is not too high compared to the temporal changes in the error: the difference can be seen by examining cases A and B in the figure.

The derivative action is ideally null in steady state, however in reality it follows and tends to amplify the measurement noise; therefore, it is only useful in the initial transient periods. It may be very useful, however it is also dangerous, above all if the measurement of the controlled variable is noisy.

CAREL

CAREL S.p.A.

Via dell'Industria, 11 - 35020 Brugine - Padova (Italy)

Tel. (+39) 049.9716611 - Fax (+39) 049.9716600

e-mail: carel@carel.com - www.carel.com

Agenzia / Agency: